

AOCS-303-9 Parts List

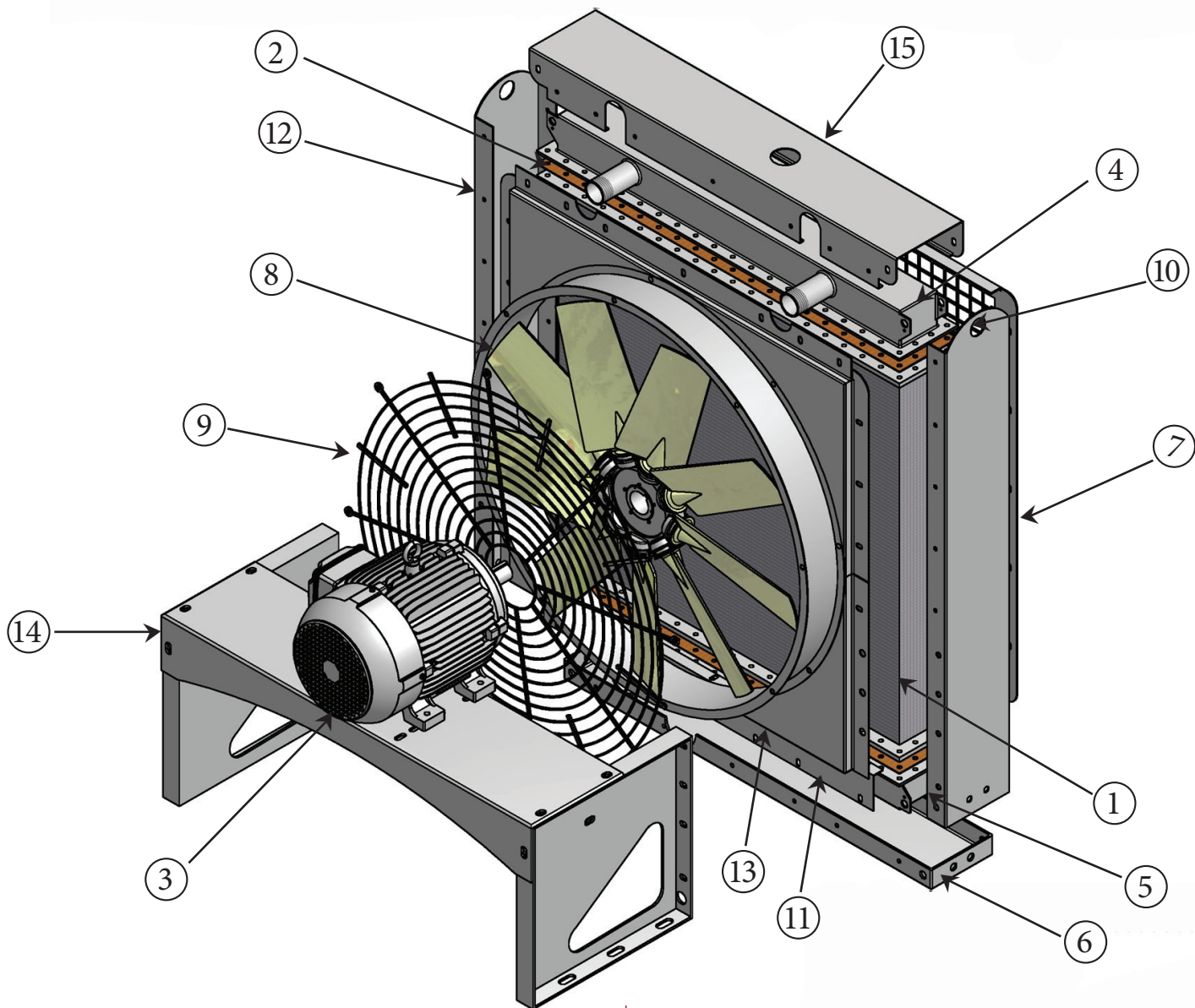

Description	Part#	Price	Stock	Description	Part#	Price	Stock
1. Core.....	110-2001.....		Stock:	9. Fan Guard	308-0016		Stock:
2. Gasket Kit.....	199-0002		Stock:	10. Right Panel.....	110-2018.....		Stock:
3. Motor	306-3002		Stock:	11. Cover Panel.....	110-2019.....		Stock:
4. Top Tank	110-2020.....		Stock:	12. Left Panel	110-2002.....		Stock:
5. Bottom Tank.....	110-2021.....		Stock:	13. Back Panel	110-2006.....		Stock:
6. Bottom Panel.....	110-1004.....		Stock:	14. Motor Bracket	110-2012.....		Stock:
7. Screen	110-2005.....		Stock:	15. Top Panel.....	110-2003.....		Stock:
8. Fan	307-0062		Stock:				