



**Shell & Tube Application Request: (For liquid to liquid heat exchangers)**

For AB2000 Series

Email form to: sales@aihti.com or engineering@aihti.com or fax to 434-757-1810

Contact Name \_\_\_\_\_ Telephone \_\_\_\_\_ Date \_\_\_\_\_

Company Name \_\_\_\_\_ Email \_\_\_\_\_

Address: \_\_\_\_\_ Fax \_\_\_\_\_

**Hot Side**

**Cold Side**

Fluid Type \_\_\_\_\_

Fluid Type \_\_\_\_\_

Density \_\_\_\_\_ lb/ft3

Density \_\_\_\_\_ lb/ft3

Viscosity \_\_\_\_\_ cP

Viscosity \_\_\_\_\_ cP

If available:

Conductivity \_\_\_\_\_ Btu/hr.ft.°F

If available:

Conductivity \_\_\_\_\_ Btu/hr.ft.°F

Specific Heat \_\_\_\_\_ Btu/lb.°F

Specific Heat \_\_\_\_\_ Btu/lb.°F

1. Flow Rate \_\_\_\_\_

1. Flow Rate \_\_\_\_\_

2. Temperature In \_\_\_\_\_

2. Temperature In \_\_\_\_\_

3. Desired Temperature Out \_\_\_\_\_

Maximum Allowable Pressure Drop:

4. Heat Load \_\_\_\_\_

Hot Side \_\_\_\_\_ Cold Side \_\_\_\_\_

To properly size the heat exchanger we need 3 of the 4 parameter on the Hot Side and 2 on the Cold Side.

Shell Material Construction:

Tube Material Construction:

Steel  Stainless Steel

Copper  90/10 Copper Nickel  Stainless Steel

ASME Code and Certified Yes  No

Require All Stainless Steel Heat Exchanger Yes  No

Comment: \_\_\_\_\_

# American Industrial Heat Transfer Inc.

Manufacturer of Quality Heat Exchangers

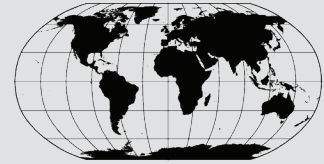

www.aihti.com

AB2000 SERIES

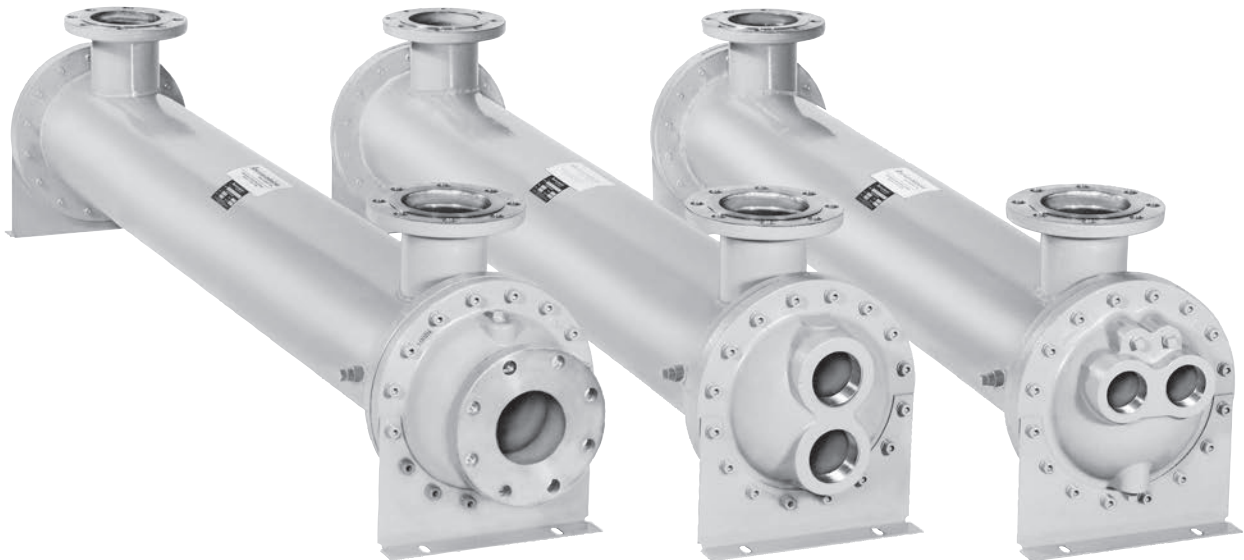

SINGLE  
PASS

TWO  
PASS

FOUR  
PASS

*Fixed Tube Bundle / Liquid Cooled*

## HEAT EXCHANGERS

- High thermal capacity.
- Large flow capacity.
- Operating pressure for tubes 150 PSI.
- Operating pressure for shell 300 PSI.
- Operating temperature 300 °F.
- Computer generated data sheet available for any application
- Can be customized to fit any applications.
- As an option, available in ASME code and certified

note: AIHTI reserves the right to make reasonable design changes without notice.

Copyright © 2019 - 2020 American Industrial Heat Transfer, Inc. 355 American Industrial Drive LaCrosse, VA 23950 tel: 434-757-1800 fax: 434-757-1810 email: sales@aihti.com

# AB 2000 Series selection

## STEP 1: Calculate the heat load

The heat load in BTU/HR or (Q) can be derived by using several methods. To simplify things, we will consider general specifications for hydraulic system oils and other fluids that are commonly used with shell & tube heat exchangers.

Terms	
GPM = Gallons Per Minute	Kw = Kilowatt (watts x 1000)
CN = Constant Number for a given fluid	T <sub>in</sub> = Hot fluid entering temperature in °F
ΔT = Temperature differential across the potential	T <sub>out</sub> = Hot fluid exiting temperature in °F
PSI = Pounds per Square Inch (pressure) of the operating side of the system	t <sub>in</sub> = Cold fluid temperature entering in °F
MHP = Horsepower of the electric motor driving the hydraulic pump	t <sub>out</sub> = Cold fluid temperature exiting in °F
	Q = BTU / HR

For example purposes, a hydraulic system has a 250 HP (186Kw) electric motor installed coupled to a pump that produces a flow of 200 GPM @ 2000 PSIG. The temperature differential of the oil entering the pump vs exiting the system is about 4.3°F. Even though our return line pressure operates below 100 psi, we must calculate the system heat load potential (Q) based upon the prime movers (pump) capability. We can use one of the following equations to accomplish this:

To derive the required heat load (Q) to be removed by the heat exchanger, apply ONE of the following. Note: The calculated heat loads may differ slightly from one formula to the next. This is due to assumptions made when estimating heat removal requirements. The factor (v) represents the percentage of the overall input energy to be rejected by the heat exchanger. The (v) factor is generally about 30% for most hydraulic systems, however it can range from 20%-70% depending upon the installed system components and heat being generated (ie. servo valves, proportional valves, etc...will increase the percentage required).

FORMULA	EXAMPLE
A) Q = GPM x CN x actual ΔT	A) Q = 200 x 210 x 4.3°F = 180,600 BTU/HR
B) Q = [(PSI x GPM) / 1714] x (v) x 2545	B) Q = [(2000x200)/1714] x .30 x 2545 = 178,179 BTU/HR
C) Q = MHP x (v) x 2545	C) Q = 250 x .30 x 2545 = 190,875 BTU/HR
D) Q = Kw to be removed x 3415	D) Q = 186 x .30 x 3415 = 190,557 BTU/HR
E) Q = HP to be removed x 2545	E) Q = 75 x 2545 = 190,875 BTU/HR

Constant for a given fluid ( CN )	
1) Oil .....	CN = 210
2) Water.....	CN = 500
3) 50% E. Glycol.....	CN = 450

## STEP 2: Calculate the Mean Temperature Difference

When calculating the MTD you will be required to choose a liquid flow rate to derive the Cold Side ΔT. If your water flow is unknown you may need to assume a number based on what is available. As a normal rule of thumb, for oil to water cooling a 2:1 oil to water ratio is used. For applications of water to water or 50 % Ethylene Glycol to water, a 1:1 ratio is common.

FORMULA	EXAMPLE
<b>HOT FLUID</b> ΔT = $\frac{Q}{CN \times GPM}$ <b>Oil</b>	$\Delta T = \frac{190,875 \text{ BTU/hr}}{210 \text{ CN} \times 200 \text{ GPM}} = 4.54^\circ\text{F} = \Delta T \text{ Rejected}$
<b>COLD FLUID</b> Δt = $\frac{\text{BTU / hr}}{CN \times \text{GPM}}$ <b>Water</b>	$\Delta t = \frac{190,875 \text{ BTU/hr}}{500 \text{ CN} \times 100 \text{ GPM (for a 2:1 ratio)}} = 3.81^\circ\text{F} = \Delta t \text{ Absorbed}$
T <sub>in</sub> = Hot Fluid entering temperature in degrees F	T <sub>in</sub> = 104.54 °F
T <sub>out</sub> = Hot Fluid exiting temperature in degrees F	T <sub>out</sub> = 100.0 °F
t <sub>in</sub> = Cold Fluid entering temperature in degrees F	t <sub>in</sub> = 90.0 °F
t <sub>out</sub> = Cold Fluid exiting temperature in degrees F	t <sub>out</sub> = 93.81 °F
$\frac{T_{out} - t_{in}}{T_{in} - t_{out}} = \frac{S[\text{smaller temperature difference}]}{L[\text{larger temperature difference}]} = \left( \frac{S}{L} \right)$	$\frac{100.0^\circ\text{F} - 90.0^\circ\text{F} = 10.0^\circ\text{F}}{104.54^\circ\text{F} - 93.81^\circ\text{F} = 10.73^\circ\text{F}} = \frac{10.0^\circ\text{F}}{10.73^\circ\text{F}} = .931$

## STEP 3: Calculate Log Mean Temperature Difference (LMTD)

To calculate the LMTD please use the following method;

LMTD<sub>i</sub> = L x M (L = Larger temperature difference from step 2.) x (M = S/L number (LOCATED IN TABLE A))

LMTD<sub>i</sub> = 10.73 x .964 (FROM TABLE A) = 10.34

To correct the LMTD<sub>i</sub> for a multipass heat exchangers calculate R & K as follows:

FORMULA	EXAMPLE	Locate the correction factor CF <sub>B</sub> (FROM TABLE B) LMTD <sub>c</sub> = LMTD <sub>i</sub> x CF <sub>B</sub> LMTD <sub>c</sub> = 10.34 x .98 = <b>10.13</b>
$R = \frac{T_{in} - T_{out}}{t_{out} - t_{in}}$	$R = \frac{104.54^\circ\text{F} - 100^\circ\text{F}}{93.81^\circ\text{F} - 90^\circ\text{F}} = \frac{4.54^\circ\text{F}}{3.81^\circ\text{F}} = \{1.191=R\}$	
$K = \frac{t_{out} - t_{in}}{T_{in} - t_{in}}$	$K = \frac{93.81^\circ\text{F} - 90^\circ\text{F}}{104.54^\circ\text{F} - 90^\circ\text{F}} = \frac{3.81^\circ\text{F}}{14.54^\circ\text{F}} = \{0.262=K\}$	

TABLE E- Flow Rate for Shell & Tube

Shell dia . Code	Max. Liquid Flow - Shell Side					Liquid Flow - Tube Side					
	Baffle Spacing					SP		TP		FP	
	A	B	C	D	E	Min.	Max.	Min.	Max.	Min.	Max.
2000	-	-	190	370	550	90	650	45	320	25	160

TABLE C

U	TUBE FLUID	SHELL FLUID
400	Water	Water
350	Water	50% E. Glycol
100	Water	Oil
300	50% E. Glycol	50% E. Glycol
90	50% E. Glycol	Oil

## STEP 4: Calculate the area required

$$\text{Required Area sq.ft.} = \frac{Q \text{ (BTU / HR)}}{\text{LMTD}_c \times U \text{ (FROM TABLE C)}} = \frac{190,875}{10.13 \times 100} = 188.4 \text{ sq.ft.}$$

## STEP 5: Selection

a) From TABLE E choose the correct series size, baffle spacing, and number of passes that best fits your flow rates for both shell and tube side. Note that the tables suggest minimum and maximum information. Try to stay within the 20-80 percent range of the indicated numbers.

Example

Oil Flow Rate = 200 GPM = Series Required from Table E = **2000 Series**  
 Baffle Spacing from Table E = **D baffle**  
 Water Flow Rate = 100 GPM = Passes required in 2000 series = **4 (FP)**

b) From TABLE D choose the heat exchanger model size based upon the sq.ft. or surface area in the series size that will accommodate your flow rate.

Example

Required Area = 188.4 sq.ft. Closest model required based upon sq.ft. & series = **AB-2007-D6-FP**

If you require a computer generated data sheet for the application, or if the information that you are trying to apply does not match the corresponding information, please contact our engineering services department for further assistance.

**TABLE A- FACTOR M/LMTD = L x M**

S/L	M	S/L	M	S/L	M	S/L	M
.01	.215	.25	.541	.50	.721	.75	.870
.02	.251	.26	.549	.51	.728	.76	.874
.03	.277	.27	.558	.52	.734	.77	.879
.04	.298	.28	.566	.53	.740	.78	.886
		.29	.574	.54	.746	.79	.890
.05	.317	.30	.582	.55	.753	.80	.896
.06	.334	.31	.589	.56	.759	.81	.902
.07	.350	.32	.597	.57	.765	.82	.907
.08	.364	.33	.604	.58	.771	.83	.913
.09	.378	.34	.612	.59	.777	.84	.918
.10	.391	.35	.619	.60	.783	.85	.923
.11	.403	.36	.626	.61	.789	.86	.928
.12	.415	.37	.634	.62	.795	.87	.934
.13	.427	.38	.641	.63	.801	.88	.939
.14	.438	.39	.648	.64	.806	.89	.944
.15	.448	.40	.655	.65	.813	.90	.949
.16	.458	.41	.662	.66	.818	.91	.955
.17	.469	.42	.669	.67	.823	.92	.959
.18	.478	.43	.675	.68	.829	.93	.964
.19	.488	.44	.682	.69	.836	.94	.970
.20	.497	.45	.689	.70	.840	.95	.975
.21	.506	.46	.695	.71	.848	.96	.979
.22	.515	.47	.702	.72	.852	.97	.986
.23	.524	.48	.709	.73	.858	.98	.991
.24	.533	.49	.715	.74	.864	.99	.995

**TABLE B- LMTD correction factor for Multipass Exchangers**

	.05	.1	.15	.2	.25	.3	.35	.4	.45	.5	.6	.7	.8	.9	1.0
.2	1	1	1	1	1	1	1	.999	.993	.984	.972	.942	.908	.845	.71
.4	1	1	1	1	1	1	.994	.983	.971	.959	.922	.855	.70		
.6	1	1	1	1	1	.992	.980	.965	.948	.923	.840				
.8	1	1	1	1	.995	.981	.965	.945	.916	.872					
1.0	1	1	1	1	.988	.970	.949	.918	.867	.770					
2.0	1	1	.977	.973	.940	.845	.740								
3.0	1	1	.997	.933	.835										
4.0	1	.993	.950	.850											
5.0	1	.982	.917												
6.0	1	.968	.885												
8.0	1	.930													
10.0	.996	.880													
12.0	.985	.720													
14.0	.972														
16.0	.958														
18.0	.940														
20.0	.915														

R

K

**TABLE D- Surface Area**

Model Number	Surface Area in Sq.ft.		
	1/4" O.D Tubing	3/8" O.D Tubing	5/8 O.D Tubing
AB-2004	155.43	110.69	60.84
AB-2005	194.29	138.36	76.05
AB-2006	233.15	166.03	91.26
AB-2007	272.00	193.70	106.47
AB-2008	310.86	221.37	121.68
AB-2009	349.72	249.04	136.88
AB-2010	388.58	276.71	152.09
AB-2011	427.43	304.38	167.30
AB-2012	466.29	332.06	182.51
AB-2013	505.15	359.73	197.72
AB-2014	544.01	387.40	212.93
AB-2015	582.86	415.07	228.14

## STANDARD CONSTRUCTION MATERIALS & RATINGS

Standard Model	AB-2000 Series	Standard Unit Ratings
Shell	Steel	Operating Pressure Tubes 150 psig
Tubes	Copper	
Baffle	Steel	Operating Pressure Shell 300 psig
Tube Sheet	Steel	
End Bonnets	Cast Iron	Operating Temperature 300 °F
Mounting Brackets	Steel	
Gasket	Hypalon Composite	

## Example Model

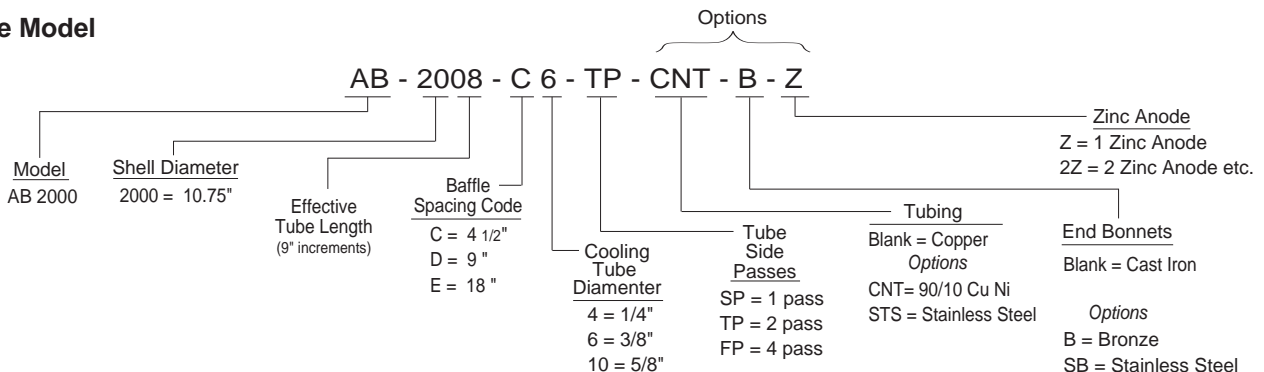

note: AIHTI reserves the right to make reasonable design changes without notice.

# AB 2000 Series performance

## Instructions

The selection chart provided contains an array of popular sizes for quick sizing. It does not provide curves for all models available. Refer to page 14 & 15 for detailed calculation information.

Computer selection data sheets for standard or special models are available through the engineering department of American Industrial. To use the followings graphs correctly, refer to the instruction notes "1-5".

- 1) HP Curves are based upon a 40°F approach temperature; for example: oil leaving a cooler at 125°F, using 85°F cooling water (125°F - 85°F = 40°F).
- 2) The oil to water ratio of 1:1 or 2:1 means that for every 1 gallon of oil circulated, a minimum of 1 or 1/2 gallon (respectively) of 85°F water must be circulated to match the curve results.

- 3) OIL PRESSURE DROP CODING:  $\oplus$  = 5 psi;  $\star$  = 10 psi;  $\circ$  = 20 psi;  $\triangle$  = 50psi. Curves that have no pressure drop code symbols indicate that the oil pressure drop is less than 5 psi for the flow rate shown.
- 4) Pressure Drop is based upon oil with an average viscosity of 100 SSU. If the average oil viscosity is other than 100 SSU, then multiply the indicated Pressure Drop by the corresponding value from corrections table A.
- 5) Corrections for approach temperature and oil viscosity are as follows:

$$H.P.(\text{In Cooler}) = H.P.(\text{Actual Heat Load}) \times \left( \frac{40}{\text{Actual Approach}} \right) \times B.$$

## HEAT ENERGY DISSIPATION RATES (Basic Stock Model)

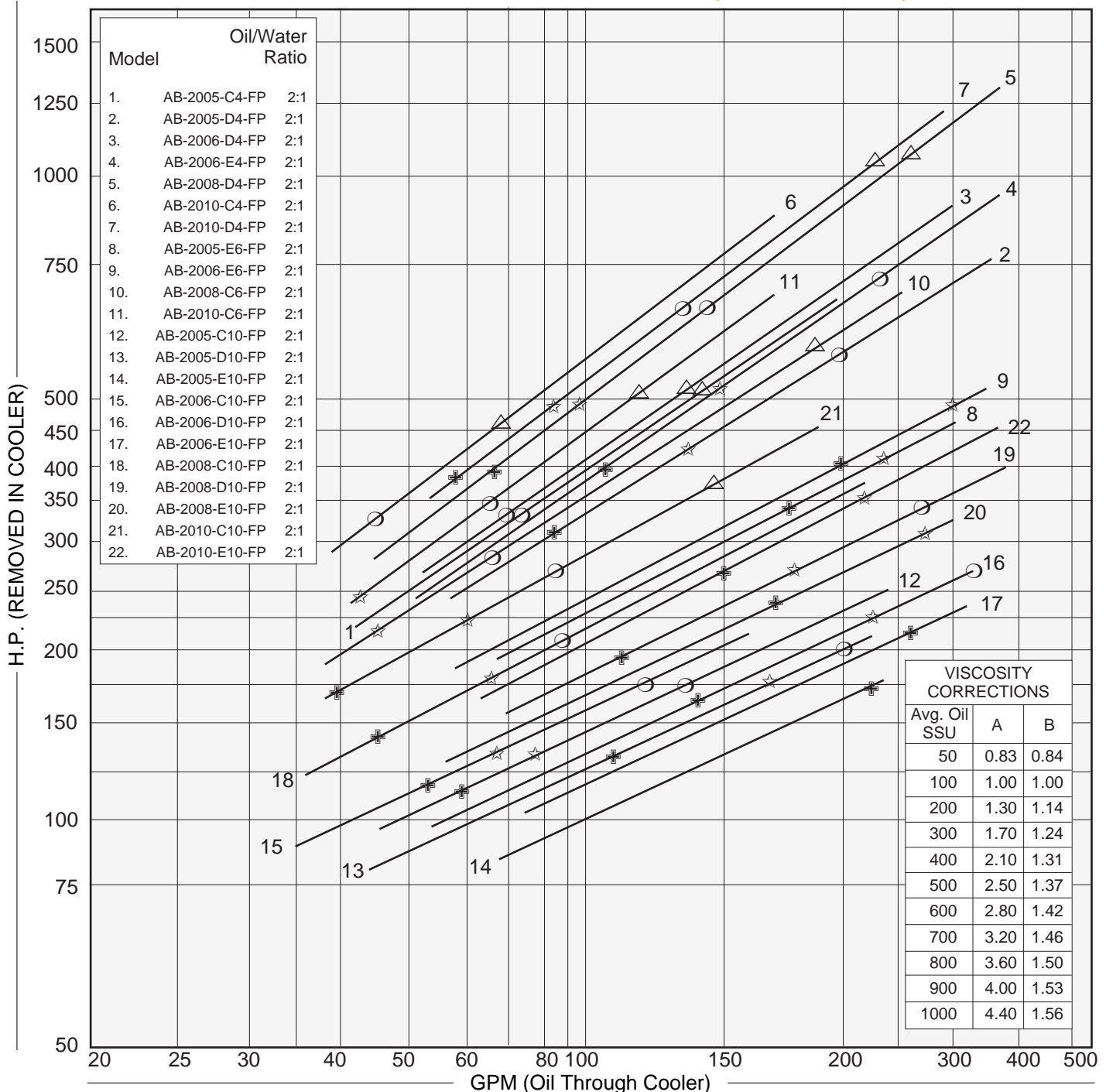

# AB 2000 Series dimensions

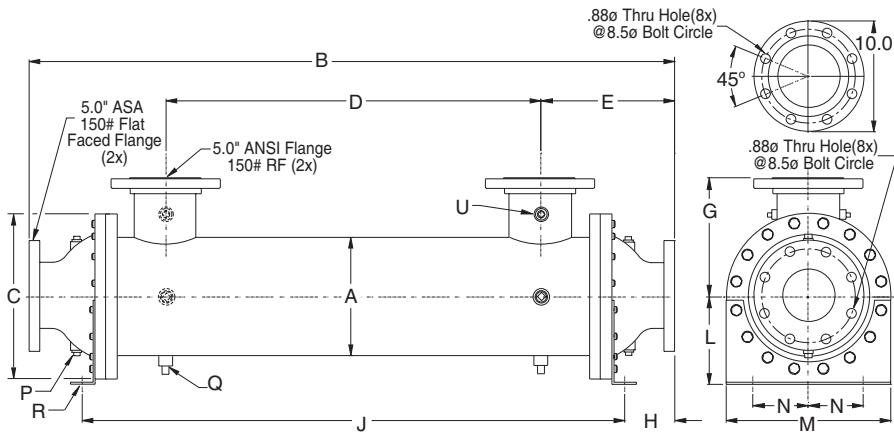

**Single Pass (SP)**

Model	B	E	H	P NPT
AB-2005	59.88	12.88	4.63	(4) .50
AB-2006	68.88			
AB-2007	77.88			
AB-2008	86.88			
AB-2009	95.88			
AB-2010	104.88			
AB-2011	113.88			
AB-2012	122.88			
AB-2013	131.88			
AB-2014	140.88			

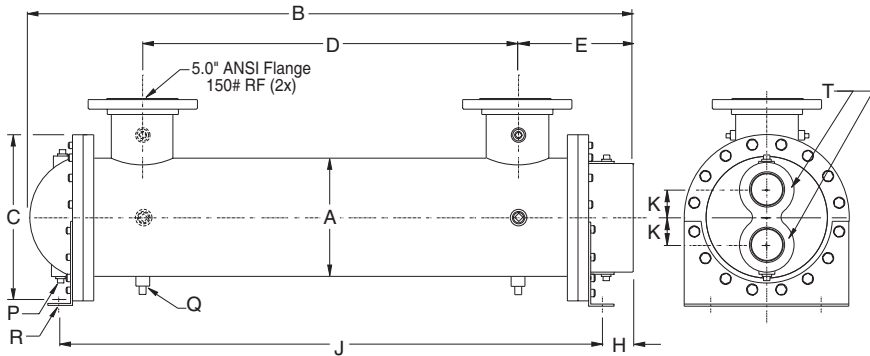

**Two Pass (TP)**

Model	B	E	H	K	P NPT	T NPT
AB-2005	55.63	10.88	2.43	2.50	(4) .50	3.00
AB-2006	64.63					
AB-2007	73.63					
AB-2008	82.63					
AB-2009	91.63					
AB-2010	100.63					
AB-2011	109.63					
AB-2012	118.63					
AB-2013	127.63					
AB-2014	136.63					

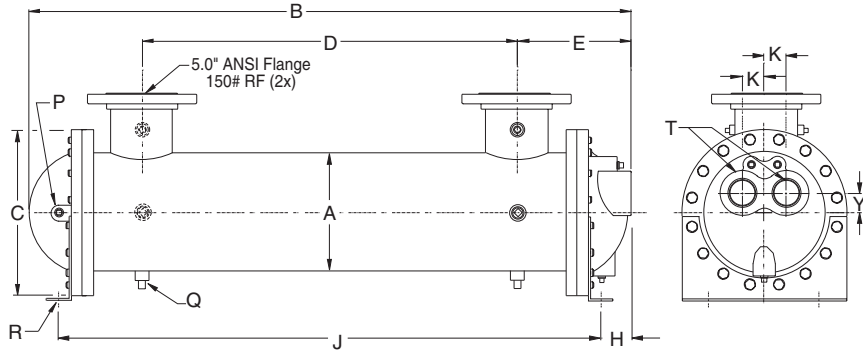

**FOUR PASS (FP)**

Model	B	E	H	K	P NPT	Y	T NPT
AB-2005	55.63	10.88	2.50	2.00	(5) .50	1.75	2.50
AB-2006	64.63						
AB-2007	73.63						
AB-2008	82.63						
AB-2009	91.63						
AB-2010	100.63						
AB-2011	109.63						
AB-2012	118.63						
AB-2013	127.63						
AB-2014	136.63						

**COMMON DIMENSIONS & WEIGHTS**

Model	A	C	D	G	J	L	M	N	Q NPT	R	U NPT	Weight	Model
AB-2005	10.75	15.00	34.12	10.75	51.00	8.00	15.00	5.00	.50 (4x)	.75"ø x 1.25" Thru Slot	.38 (2x)	670	AB-2005
AB-2006			43.12		60.00							720	AB-2006
AB-2007			52.12		69.00							770	AB-2007
AB-2008			61.12		78.00							820	AB-2008
AB-2009			70.12		87.00							870	AB-2009
AB-2010			79.12		96.00							820	AB-2010
AB-2011			88.12		105.00							970	AB-2011
AB-2012			97.12		114.00							1020	AB-2012
AB-2013			106.12		123.00							1070	AB-2013
AB-2014			115.12		132.00							1120	AB-2014

## PIPING HOOK-UP

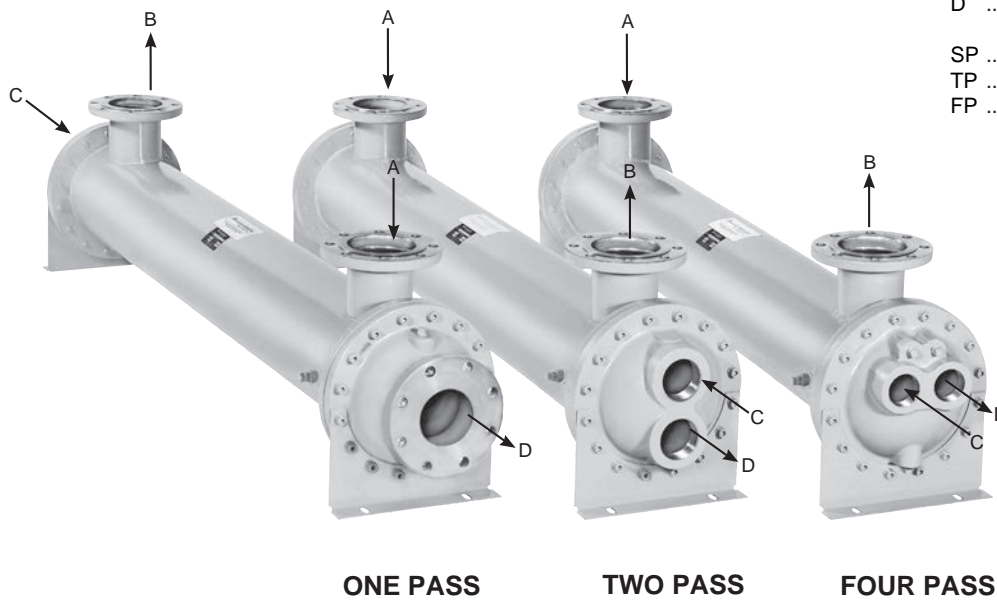

A ..... Hot fluid to be cooled  
 B ..... Cooled fluid  
 C ..... Cooling water in  
 D ..... Cooling water out

SP ..... Single Pass  
 TP ..... Two Pass  
 FP ..... Four Pass

**ONE PASS**

**TWO PASS**

**FOUR PASS**

### Receiving / Installation

a) Inspect unit for any shipping damage before uncrating. Indicate all damages to the trucking firms' delivery person, and mark it on the receiving bill before accepting the freight. Make sure that there is no visible damage to the outside surface of the heat exchanger. The published weight information located in this brochure is approximate. True shipment weights are determined at the time of shipping and may vary. Approximate weight information published herein is for engineering approximation purposes and should not be used for exact shipping weight. Since the warranty is based upon the unit date code located on the model identification tags, removal or manipulation of the identification tags will void the manufacturer's warranty.

b) When handling the shell & tube heat exchanger, special care should be taken to avoid dropping the unit since mishandling could cause the heat exchanger to crack and leak externally. Mishandling of the unit is not covered under the manufacturer's warranty. All units are shipped with partial wood/corrugated cardboard containers for safe handling.

c) Storage: American Industrial heat exchangers are protected against the elements during shipment. If the heat exchanger cannot be installed and put into operation immediately upon receipt, certain precautions are required to prevent deterioration during storage. The responsibility for integrity of the heat exchanger(s) is assumed by the user. American Industrial will not be responsible for damage, corrosion, or other deterioration of the heat exchanger during transit or storage.

Proper storage practices are important when considering the high costs of repair or replacement, and the possible delays for items which require long lead times for manufacture. The following listed practices are provided solely as a convenience to the user, who shall make their own decision on whether to use all or any of them.

- 1) Heat exchangers not to be placed in immediate service, require precautionary measures to prevent corrosion or contamination.
- 2) Heat exchangers made of ferrous materials, may be pressure-tested using compressed air at the factory. Residual oil coating on the inside surfaces of the heat exchanger(s) as a result of flushing does not discount the possibility of internal corrosion. Upon receipt, fill the heat exchanger(s) with the appropriate grade of oil or apply a corrosion preventing inhibitor for storage.
- 3) Corrosion protection compounds for interior surfaces for long term storage or other applications are applied solely at the request of customers. Upon request, American Industrial can provide a customer approved corrosion preventative if available when included in the original purchase order specifications.
- 4) Remove all dirt, water, ice, or snow and wipe dry before moving heat exchanger(s) into storage. Heat exchangers are generally shipped

note: AIHTI reserves the right to make reasonable design changes without notice.

empty, open drain plugs to remove any accumulated condensation moisture, then reseal. Accumulation of moisture usually indicates corrosion has already started and remedial action should be taken.

- 5) Store in a covered, environmentally stable area. The ideal storage environment for heat exchangers is in a dry, low-humidity atmosphere which is sealed to prevent the entry of blowing dust, rain, or snow. Maintain in atmospheric temperatures between 70°F and 105°F (Large temperature swings may cause condensation and moisture to form on steel components, threads, shell, etc...) Use thermometers and humidity indicators and maintain the atmosphere at 40% relative humidity, or lower.

d) Standard Enamel Coating: American Industrial provides its standard products with a normal base coat of oil base air cure enamel paint. The enamel paint is applied as a temporary protective and esthetic coating prior to shipment. While the standard enamel coating is durable, American Industrial does not warranty it as a long-term finish coating. It is strongly suggested that a more durable final coating be applied after installation or prior to long-term storage in a corrosive environment to cover any accidental scratches, enhance esthetics, and further prevent corrosion. It is the responsibility of the customer to provide regular maintenance against chips, scratches, etc... and regular touch up maintenance must be provided for long-term benefits and corrosion prevention.

e) Special Coatings: American Industrial offers as customer options, Air-Dry Epoxy, and Heresite (Air-Dry Phenolic) coatings at additional cost. American Industrial offers special coatings upon request, however American Industrial does not warranty coatings to be a permanent solution for any equipment against corrosion. It is the responsibility of the customer to provide regular maintenance against chips, scratches, etc... and regular touch up maintenance must be provided for long-term benefits and corrosion prevention.

f) American Industrial recommends that the equipment supplied should be installed by qualified personnel who have solid understanding of system design, pressure and temperature ratings, and piping assembly. Verify the service conditions of the system prior to applying any shell & tube heat exchanger. If the system pressure or temperature does not fall within the parameters on model rating tag located on the heat exchanger, contact our factory prior to installation or operation.

g) Plan the installation to meet the requirements indicated on the piping installation diagram as illustrated above. It is recommended to put the hot fluid to be cooled through the shell side and the cold fluid through the tube side. The indicated port assembly sequence in the diagram maxi-

# AB 2000 Series installation & maintenance

mizes the performance, and minimizes the possibility of thermal shock. In instances where the fluids are required to be reversed, *hot fluid in the tubes and cold fluid in the shell* the heat exchanger will work with reduced performance. Installation may be vertical or horizontal or a combination thereof. However, the installation must allow for complete draining of the heat exchanger regardless of Single Pass, Two Pass, or four pass construction. Complete drainage is important to prevent the heat exchanger from freezing, over-heating of a fluid, or mineral deposit buildup.

For fixed bundle heat exchangers, provide sufficient clearance at one end to allow for the removal or replacement of tubes. On the opposite end, provide enough space to allow removal of the complete bonnet to provide sufficient clearance to permit tube rolling and cleaning. Allow accessible room for scheduled cleaning as needed. Include thermometer wells and pressure gauge pipe ports in piping to and from the heat exchanger located as close to the heat exchanger as possible. For more information please contact American Industrial.

h) It is recommended to use flexible hose wherever possible to reduce vibration and allow slight movement. However, hoses are not required. Hydraulic carrying lines should be sized to handle the appropriate flow and to meet system pressure drop requirements based upon the systems parameters, and not based upon the units supply and return connection size. We recommend that a low cracking pressure direct acting relief valve be installed at the heat exchanger inlet to protect it from pressure spikes by bypassing oil in the event the system experiences a high flow surge. If preventative filtration is used it should be located ahead of the cooler on both shell and tube side to catch any scale or sludge from the system before it enters the cooler. Failure to install filters ahead of the heat exchanger could lead to possible heat exchanger failure due to high pressure if the system filters plug.

i) Standard shell & tube coolers are built with a rolled tube-sheet construction. However, the differential operating temperature between the entering shell side fluid and the entering tube side fluid should not exceed 150°F. If this condition exists, a severe thermal shock could occur leading to product failure and mixing of the fluids. For applications with a differential temperatures of 150°F or more, we recommend using a series with a floating tube-sheet, u-tube, or expansion joint to reduce the potential for the effects of thermal shock.

j) Water requirements vary from location to location. If the source of cooling water is from other than a municipal water supply, it is recommended that a water strainer be installed ahead of the heat exchanger to prevent dirt and debris from entering and clogging the flow passages. If a water modulating valve is used it is recommended to be installed at the inlet to the cooler to regulate the water flow.

k) For steam service, or other related applications, please consult our engineering department for additional information.

## Maintenance

a) Inspect the heat exchanger for loosened bolts, connections, rust spots, corrosion, and for internal or external fluid leakage. Any corroded surfaces should be cleaned and recoated with paint.

b) Shell side: In many cases with clean hydraulic system oils it will not be necessary to flush the interior of the shell side of the cooler. In circumstances where the quality of hydraulic fluid is in question, the shell side should be disconnected and flushed on a yearly basis with a clean flushing oil/solvent to remove any sludge that has been deposited. For severe cases where the unit is plugged and cannot be flushed clean with solvent, the heat exchanger should be replaced to maintain the proper cooling performance.

c) Tube side: In many cases it will be necessary to clean the tube side of the heat exchanger due to poor fluid quality, debris, calcium deposits, corrosion, mud, sludge, seaweed, etc.... To clean the tube side, flush with clean water or any good quality commercial cleaner that does not attack the particular material of construction. With straight tube heat exchangers you can use a rod to carefully push any debris out of the tubes.

d) Zinc anodes are normally used to reduce the risk of failure due to electrolysis. Zinc anodes are a sacrificial component designed to wear and dissolve through normal use. Normally, zinc anodes are applied to the

water supply side of the heat exchanger. Depending upon the amount of corrosive action, one, two, three, or more anodes can be applied to help further reduce the risk of failure. American Industrial Heat Transfer, Inc. offers zinc anodes as an option, to be specified and installed at the request our customers. It is the responsibility of the customer to periodically check and verify the condition of the zinc anode and replace it as needed.

Applications vary due to water chemical makeup and quality, material differences, temperature, flow rate, piping arrangements, and machine grounding. For those reasons, zinc anodes do not follow any scheduled factory predetermined maintenance plan moreover they must be checked routinely by the customer, and a maintenance plan developed based upon the actual wear rate.

If substantial wear occurs or zinc dissolves without replacement, premature failure or permanent damage may occur to the heat exchanger. American Industrial does not warranty customer applications. It is the responsibility of the customer to verify and apply the proper system materials of construction and overall system requirements. Failures resulting from properly applied or misapplied use of zinc anode(s) into non-specified or specified applications will be the sole responsibility of the customer.

e) A routine maintenance schedule should be developed and adjusted to meet your systems requirements based upon water quality, etc.... Failure to regularly maintain and clean your heat exchanger can result in a reduction in operational performance and life expectancy.

Note: Since applications can vary substantially, the installation and maintenance information contained in this catalog should be used as a basic guideline. The safe installation, maintenance, and use of any American Industrial Heat Transfer, Inc. heat exchanger are solely the responsibility of the user.

## ACCESSORIES: THERMOSTATIC MODULATING WATER VALVE WITH BULB WELL ASSEMBLY

(for Shell & Tube Heat Exchangers And Air/Oil Coolers)

See Page 273

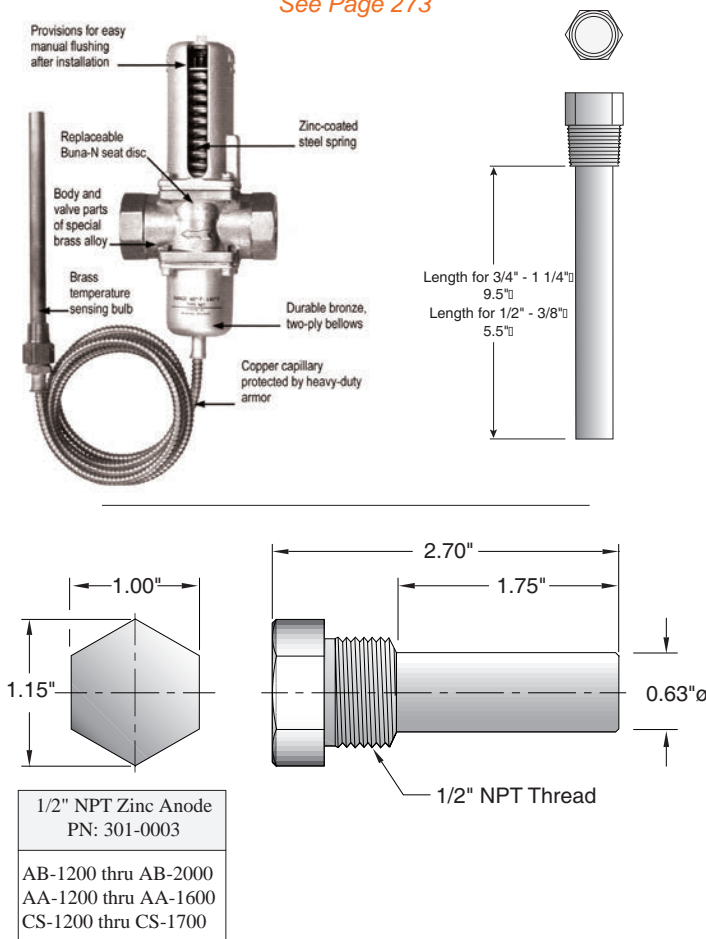



# ACCESSORIES *shell & tube heat exchangers*

## 56T THERMOSTATIC MODULATING WATER VALVE WITH BULB WELL ASSEMBLY

(for Shell & Tube Heat Exchangers And Air/Oil Coolers)

### SPECIFICATIONS

<b>Sizes</b>	0.375", 0.50", 0.75", 1.00", 1.25" FPT
<b>Fluid Pressure</b>	125psi (max.)
<b>Standard Temperature</b>	40° - 100° F., 60° - 140° F., 100° - 175° F., 125° - 200° F., 140° - 240° F., 200° - 275°F.
<b>Body</b>	Brass alloy casting
<b>Valve Parts</b>	Brass alloy
<b>Standard Capillary Length</b>	6' & 20' foot
<b>Standard Bulbs</b>	For 3/8" & 1/2" valve sizes: 5/8" x 6 with 3/4" union connections. For 3/4" & 1" valve sizes: 5/8" x 8-1/4" with 3/4" union connections. Stainless steel construction available.
<b>Standard Bulb Mounting</b>	3/4" NPT
<b>Seat Disk</b>	Buna-N-replaceable
<b>Seat Bead</b>	Stainless Steel - replaceable

### APPLICATION INFORMATION

- Built for rugged machine tool and hydraulic applications.
- Adjustable temperature range to meet your requirements.
- Quick response to temperature changes.
- Extra heavy-duty direct acting bellows for longer service.

Note: Please consult factory if a non-cataloged temperature is required.

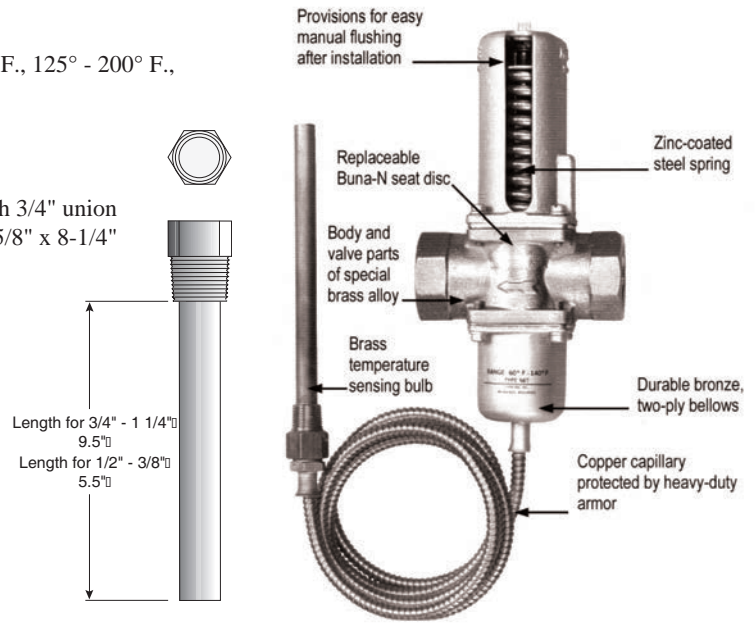

The type 56-T valve gives smooth regulation of water and other fluids. It's designed for the most rugged application. For example: hydraulic power packaging equipment, hydraulic presses, plastic molding equipment, and anywhere reliability in temperature control is demanded. The type 56-t valve is a better designed product that won't leak or chatter. To insure dependability, every valve is factory tested three times in different temperature baths. Extra performance can be expected of the bellows also. They are direct acting with sturdy walls, and the inner spring is zinc coated. The seat beads are stainless steel to resist the erosive effects of *wire drawing* and provide longer life for your needs. Additional features include mounting in any position, Buna-N seat disc, and manual flushing.

### Thermostatic Modulating Water Valve

Part Number	Description	
	Size NPT	Temp. Range
310-1001	3/8"	60 °F - 140 °F
310-1004	1/2"	60 °F - 140 °F
310-1008	3/4"	60 °F - 140 °F
310-1014	1"	60 °F - 140 °F
310-1020	1-1/4"	60 °F - 140 °F
310-1046	1-1/2"	60 °F - 140 °F
310-1047	2"	60 °F - 140 °F
310-1025	3/8"	100 °F - 175 °F
310-1005	1/2"	100 °F - 175 °F
310-1010	3/4"	100 °F - 175 °F
310-1015	1"	100 °F - 175 °F
310-1026	1-1/4"	100 °F - 175 °F

Bulb Well	
Part Number Brass	Part Number Stainless Steel
310-2001	310-2003
310-2001	310-2003
310-2002	310-2004
310-2002	310-2004
310-2002	310-2004
310-2002	310-2004
310-2001	310-2003
310-2001	310-2003
310-2002	310-2004
310-2002	310-2004
310-2002	310-2004

### Zinc Anode List Prices

Description	
Part Number	Size NPT
301-0004	3/8" NPT
301-0003	1/2" NPT

