



Shell & Tube Application Request: *(For liquid to liquid heat exchangers)*

For CS2400 - 4800 Series

Email form to: sales@aihti.com or engineering@aihti.com or fax to 434-757-1810

Contact Name _____ Telephone _____ Date _____

Company Name _____ Email _____

Address: _____ Fax _____

Hot Side

Cold Side

Fluid Type _____

Fluid Type _____

Density _____ lb/ft³

Density _____ lb/ft³

Viscosity _____ cP

Viscosity _____ cP

If available:

Conductivity _____ Btu/hr.ft.°F

If available:

Conductivity _____ Btu/hr.ft.°F

Specific Heat _____ Btu/lb.°F

Specific Heat _____ Btu/lb.°F

1. Flow Rate _____

1. Flow Rate _____

2. Temperature In _____

2. Temperature In _____

3. Desired Temperature Out _____

Maximum Allowable Pressure Drop:

4. Heat Load _____

Hot Side _____ Cold Side _____

To properly size the heat exchanger we need 3 of the 4 parameter on the Hot Side and 2 on the Cold Side.

Fixed Tube Bundle Removable Tube Bundle U-Tube Fixed Tube Bundle U-Tube Removable Tube Bundle

Shell Material Construction:

Tube Material Construction:

End Bonnets Material:

Steel Stainless Steel

Copper

Steel

Tube Sheet Material

90/10 Copper Nickel

Stainless Steel

Steel Stainless Steel

Stainless Steel

Brass (Applies to removable bundle only)

Require All Stainless Steel Heat Exchanger Yes No

ASME Code and Certified Yes No

Comment: _____

American Industrial Heat Transfer Inc.

Manufacturer of Quality Heat Exchangers



www.aihti.com

CS 2400 - 4800 SERIES

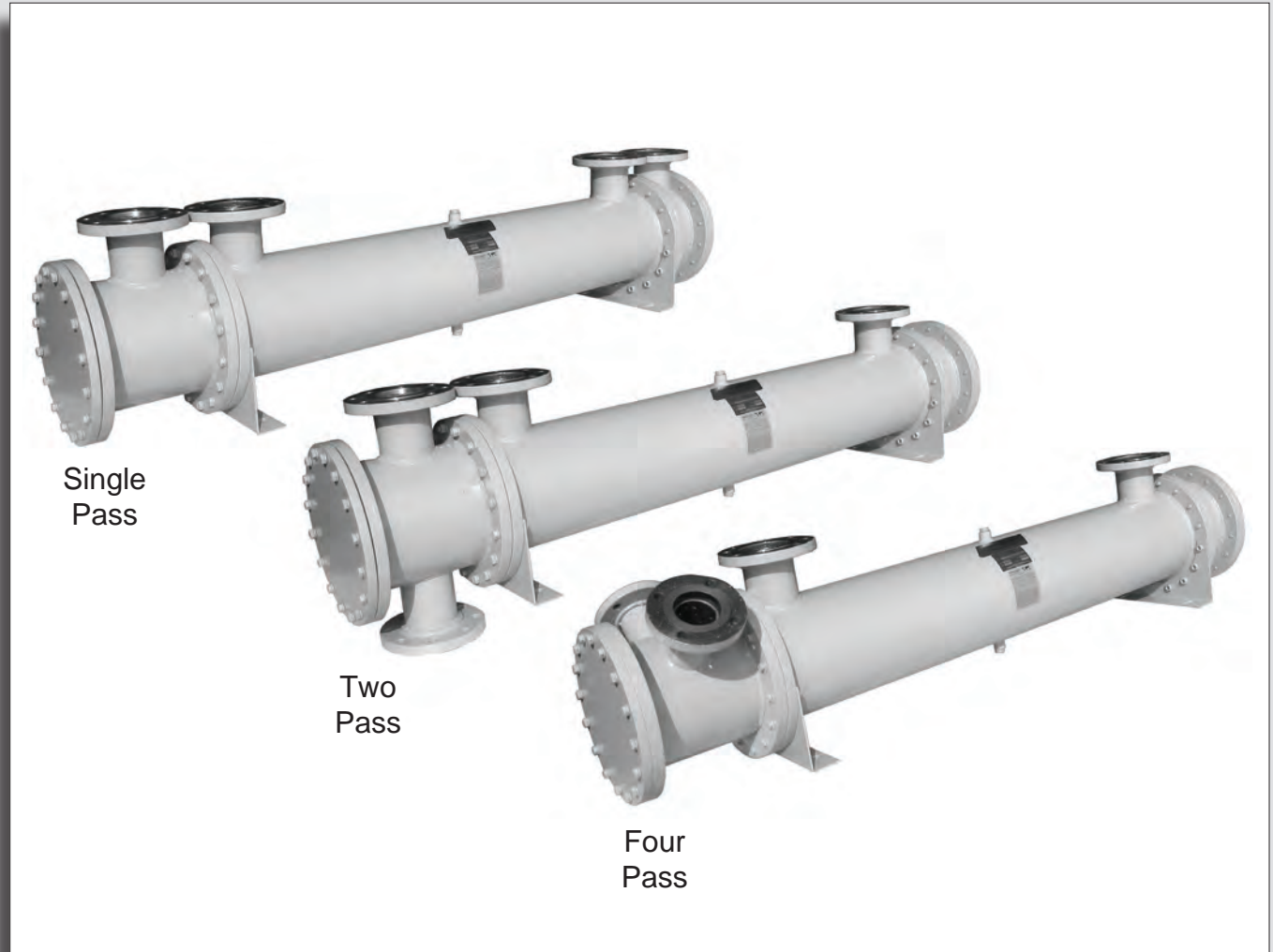

Fixed Tube Bundle / Liquid Cooled

HEAT EXCHANGERS

- High thermal capacity.
- Large flow capacity.
- Operating pressure for tubes 150 PSI.
- Operating pressure for shell 300 PSI.
- Operating temperature 300 °F.
- Computer generated data sheet available for any application
- As an option, available in ASME code and certified
- Can be customized to fit any applications.

note: AIHTI reserves the right to make reasonable design changes without notice.

Copyright © 2019 - 2020 American Industrial Heat Transfer, Inc. 355 American Industrial Drive LaCrosse, VA 23950 tel: 434-757-1800 fax: 434-757-1810 email: sales@aihti.com

CS 2400 - CS 4800 Series overview

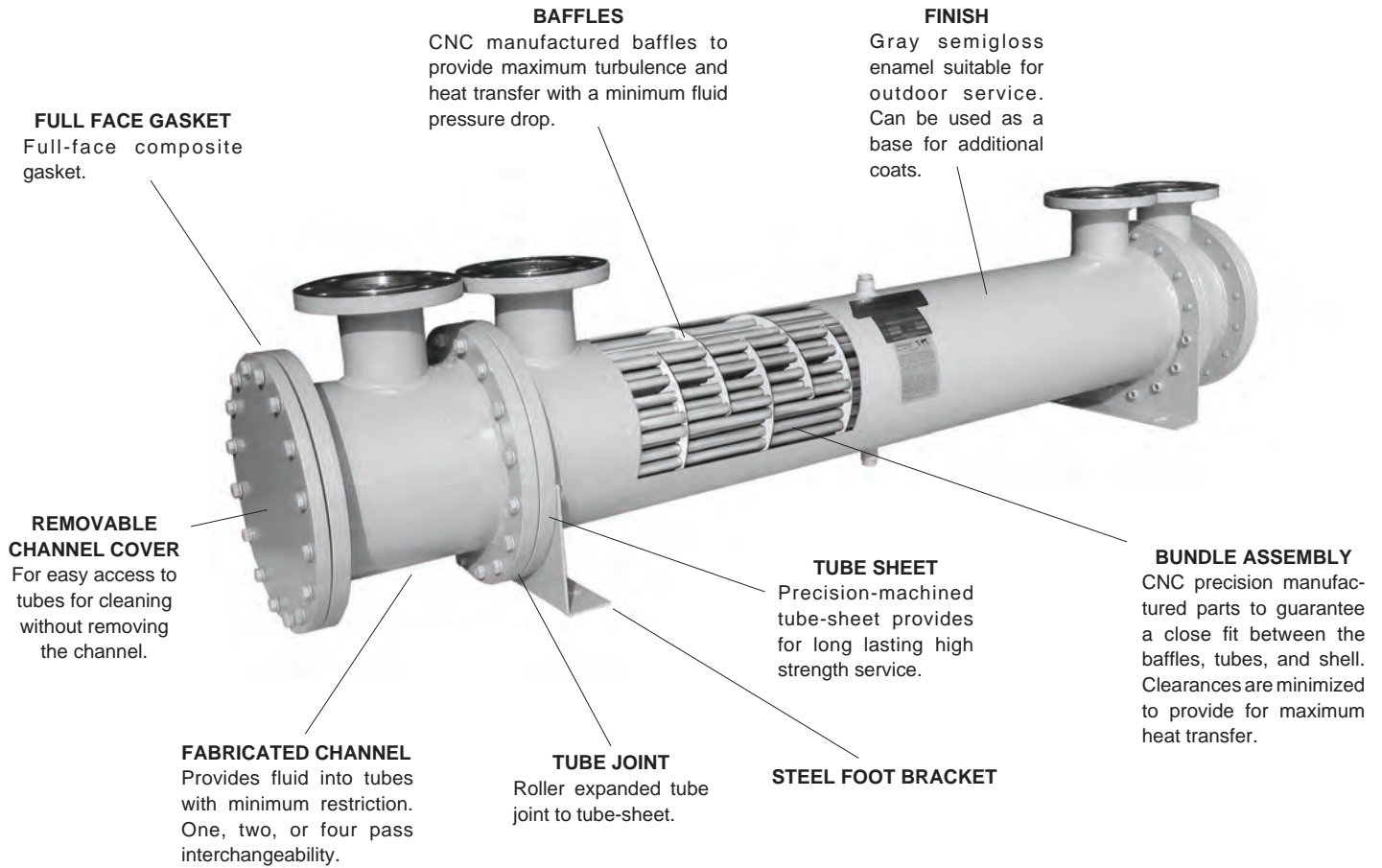

UNIT CODING

Example Model

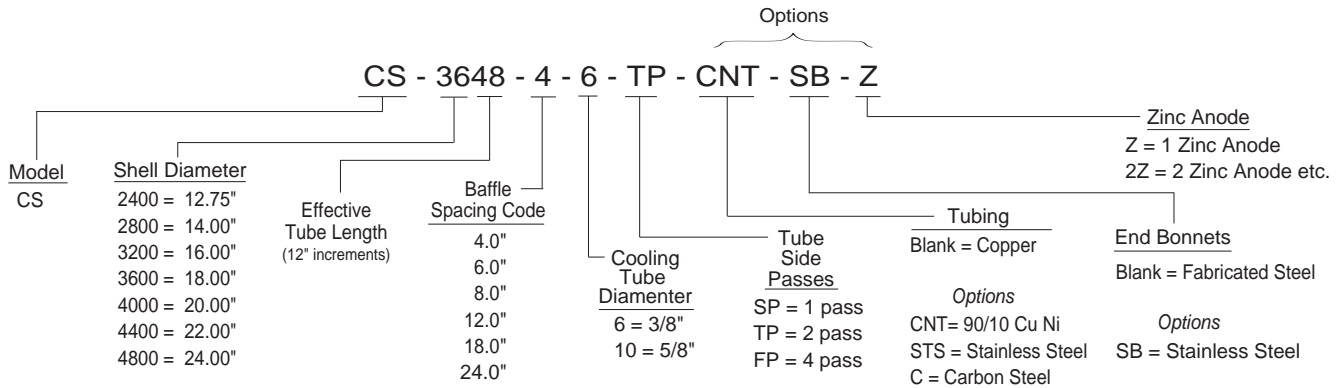

STANDARD CONSTRUCTION MATERIALS & RATINGS

Standard Model	CS 2400 - 4800	Options	
Shell	Steel	Stainless Steel	Operating Pressure Tubes 150 psig Operating Pressure Shell 300 psig Operating Temperature 300 °F
Tubes	Copper	90/10 Copper Nickel / Stainless Steel	
Baffle	Steel	Brass / Stainless Steel	
Tube Sheet	Steel	Stainless Steel	
End Bonnets	Fabricated Steel	Stainless Steel	
Mounting Brackets	Steel	Steel	
Gasket	Hypalon Composite	O-Ring	

STEP 1: Calculate the heat load

The heat load in BTU/HR or (Q) can be derived by using several methods. To simplify things, we will consider general specifications for hydraulic system oils and other fluids that are commonly used with shell & tube heat exchangers.

Terms	
GPM = Gallons Per Minute	Kw = Kilowatt (watts x 1000)
CN = Constant Number for a given fluid	T _{in} = Hot fluid entering temperature in °F
ΔT = Temperature differential across the potential	T _{out} = Hot fluid exiting temperature in °F
PSI = Pounds per Square Inch (pressure) of the operating side of the system	t _{in} = Cold fluid temperature entering in °F
MHP = Horsepower of the electric motor driving the hydraulic pump	t _{out} = Cold fluid temperature exiting in °F
	Q = BTU / HR

For example purposes, a hydraulic system has a total input 1200 HP (894Kw) electric motor installed coupled to a pump that produces a flow of 600 GPM @ 3000 PSIG. The temperature differential of the oil entering the pump vs exiting the system is about 6.6°F. Even though the return line pressure operates below 200 psi, calculate the system heat load potential (Q) based upon the prime movers (pump) capability, cooling fluid is water @ 80°F use one of the following equations to accomplish this:

To derive the required heat load (Q) to be removed by the heat exchanger, apply ONE of the following. Note: The calculated heat loads may differ slightly from one formula to the next. This is due to assumptions made when estimating heat removal requirements. The factor (ν) represents the percentage of the overall input energy to be rejected by the heat exchanger. The (ν) factor is generally about 30% for most hydraulic systems, however it can range from 20%-70% depending upon the installed system components and heat being generated (ie. servo valves, proportional valves, etc...will increase the percentage required).

FORMULA	EXAMPLE
A) Q = GPM x CN x actual ΔT	A) Q = 600 x 210 x 6.6°F = 831,600 BTU/HR
B) Q = [(PSI x GPM) / 1714] x (ν) x 2545	B) Q = [(3000x600)/1714] x .30 x 2545 = 801,808 BTU/HR
C) Q = MHP x (ν) x 2545	C) Q = 1200 x .30 x 2545 = 916,200 BTU/HR
D) Q = Kw to be removed x 3415	D) Q = 894 x .30 x 3415 = 915,909 BTU/HR
E) Q = HP to be removed x 2545	E) Q = 300 x 2545 = 736,500 BTU/HR

Constant for a given fluid (CN)

- 1) Oil CN = 210
- 2) Water..... CN = 500
- 3) 50% E. Glycol..... CN = 450

STEP 2: Calculate the Mean Temperature Difference

When calculating the MTD you will be required to choose a liquid flow rate to derive the Cold Side ΔT. If the water flow is unknown you may need to assume a number based on what is available. As a normal rule of thumb, for oil to water cooling a 2:1 oil to water ratio is used. For applications of water to water or 50 % Ethylene Glycol to water, a 1:1 ratio is common.

FORMULA	EXAMPLE (from step 1,item c)
<p>HOT FLUID Oil</p> $\Delta T = \frac{Q}{CN \times GPM}$	$\Delta T = \frac{916,200 \text{ BTU/hr}}{210 \text{ CN} \times 600 \text{ GPM}} = 7.37^\circ\text{F} = \Delta T \text{ Rejected}$
<p>COLD FLUID Water</p> $\Delta t = \frac{BTU / hr}{CN \times GPM}$	$\Delta t = \frac{916,200 \text{ BTU/hr}}{500 \text{ CN} \times 300 \text{ GPM}} = 3.81^\circ\text{F} = \Delta t \text{ Absorbed}$
T _{in} = Hot Fluid entering temperature in degrees F	T _{in} = 117.3 °F
T _{out} = Hot Fluid exiting temperature in degrees F	T _{out} = 110.0 °F
t _{in} = Cold Fluid entering temperature in degrees F	t _{in} = 80.0 °F
t _{out} = Cold Fluid exiting temperature in degrees F	t _{out} = 86.1 °F
$\frac{T_{out} - t_{in}}{T_{in} - t_{out}} = \frac{S[\text{smaller temperature difference}]}{L[\text{larger temperature difference}]} = \left(\frac{S}{L} \right)$	$\frac{110.0^\circ\text{F} - 80.0^\circ\text{F}}{117.3^\circ\text{F} - 86.1^\circ\text{F}} = \frac{30.0^\circ\text{F}}{31.2^\circ\text{F}} = .962$

STEP 3: Calculate Log Mean Temperature Difference (LMTD)

To calculate the LMTD please use the following method;

L = Larger temperature difference from step 2.

M = S/L number (LOCATED IN TABLE A). .962 = .980

LMTD_i = L x M

To correct the LMTD_i for a multipass heat exchangers calculate **R** & **K** as follows:

$$LMTD_i = 31.2 \times .980 \text{ (FROM TABLE A)} = 30.6$$

FORMULA	EXAMPLE
$R = \frac{T_{in} - T_{out}}{t_{out} - t_{in}}$	$R = \frac{117.3^\circ\text{F} - 100^\circ\text{F}}{86.1^\circ\text{F} - 90^\circ\text{F}} = \frac{17.3^\circ\text{F}}{6.1^\circ\text{F}} = \{2.82=R\}$
$K = \frac{t_{out} - t_{in}}{T_{in} - t_{in}}$	$K = \frac{86.1^\circ\text{F} - 80^\circ\text{F}}{117.3^\circ\text{F} - 80^\circ\text{F}} = \frac{6.1^\circ\text{F}}{37.3^\circ\text{F}} = \{.163=K\}$

Locate the correction factor CF_B
(FROM TABLE B)
LMTD_c = LMTD_i x CF_B
LMTD_c = 30.6 x .997 = **30.5**

STEP 4: Calculate the area required

$$\text{Required Area sq.ft.} = \frac{Q \text{ (BTU / HR)}}{LMTD_c \times U \text{ (FROM TABLE C)}} = \frac{916,200}{30.5 \times 100} = \mathbf{300.4 \text{ sq.ft.}}$$

CS 2400 - 4800 Series selection

STEP 5: Selection

a) From TABLE E choose the correct series size, baffle spacing, and number of passes that best fits your flow rates for both shell and tube side. Note that the tables suggest minimum and maximum information. Try to stay within the 20-80 percent range of the indicated numbers.

Example

Oil Flow Rate = 600 GPM = Series Required from Table E = **2400 Series**
 Baffle Spacing from Table E = **18 baffle**

Water Flow Rate = 300 GPM = Passes required in 2000 series = **TP**

b) From TABLE D choose the heat exchanger model size based upon the sq.ft. or surface area in the series size that will accommodate your flow rate.

Example

Required Area = 300.4 sq.ft. Closest model required based upon sq.ft. & series = **CS-2472-12-6-TP**

If you require a computer generated data sheet for the application, or if the information that you are trying to apply does not match the corresponding information, please contact our engineering services department for further assistance.

Shell Dia. Code	Max. Liquid Flow - Shell Side						Liquid Flow - Tube Side					
	4	6	8	12	18	24	SP		TP		FP	
							Min.	Max.	Min.	Max.	Min.	Max.
2400	155	235	310	470	700	930	135	1080	70	535	34	265
2800	170	255	345	510	770	1030	166	1320	83	660	42	330
3200	200	295	395	590	890	1175	221	1760	110	880	55	440
3600	225	335	445	665	1000	1330	284	2275	142	1135	71	565
4000	250	375	495	745	1120	1490	355	2845	177	1420	89	710
4400	275	410	550	820	1230	1640	435	3480	218	1740	109	870
4800	300	450	600	895	1345	1790	522	4170	261	2085	130	1040

TABLE C

U	TUBE FLUID	SHELL FLUID
400	Water	Water
350	Water	50% E. Glycol
100	Water	Oil
300	50% E. Glycol	50% E. Glycol
90	50% E. Glycol	Oil

TABLE A- FACTOR M/LMTD = L x M

S/L	M	S/L	M	S/L	M	S/L	M
.01	.215	.26	.541	.50	.721	.75	.870
.02	.251	.27	.558	.52	.734	.77	.864
.03	.277	.28	.566	.53	.740	.78	.886
.04	.298	.29	.574	.54	.746	.79	.890
.05	.317	.30	.582	.55	.753	.80	.896
.06	.334	.31	.589	.56	.759	.81	.902
.07	.350	.32	.597	.57	.765	.82	.907
.08	.364	.33	.604	.58	.771	.83	.913
.09	.378	.34	.612	.59	.777	.84	.918
.10	.391	.35	.619	.60	.783	.85	.923
.11	.403	.36	.626	.61	.789	.86	.928
.12	.415	.37	.634	.62	.795	.87	.934
.13	.427	.38	.641	.63	.801	.88	.939
.14	.438	.39	.648	.64	.806	.89	.944
.15	.448	.40	.655	.65	.813	.90	.949
.16	.458	.41	.662	.66	.818	.91	.955
.17	.469	.42	.669	.67	.823	.92	.959
.18	.478	.43	.675	.68	.829	.93	.964
.19	.488	.44	.682	.69	.836	.94	.970
.20	.497	.45	.689	.70	.840	.95	.975
.21	.506	.46	.695	.71	.848	.96	.979
.22	.515	.47	.702	.72	.852	.97	.986
.23	.524	.48	.709	.73	.858	.98	.991
.24	.533	.49	.715	.74	.864	.99	.995

TABLE B- LMTD correction factor for Multipass Exchangers

	.05	.1	.15	.2	.25	.3	.35	.4	.45	.5	.6	.7	.8	.9	1.0
.2	1	1	1	1	1	1	1	.999	.993	.984	.972	.942	.908	.845	.71
.4	1	1	1	1	1	1	.994	.983	.971	.959	.922	.855	.70		
.6	1	1	1	1	1	.992	.980	.965	.948	.923	.840				
.8	1	1	1	1	.995	.981	.965	.945	.916	.872					
1.0	1	1	1	1	.988	.970	.949	.918	.867	.770					
2.0	1	1	.977	.973	.940	.845	.740								
3.0	1	1	.997	.933	.835										
4.0	1	.993	.950	.850											
5.0	1	.982	.917												
6.0	1	.968	.885												
8.0	1	.930													
10.0	.996	.880													
12.0	.985	.720													
14.0	.972														
16.0	.958														
18.0	.940														
20.0	.915														

R

K

TABLE D- Surface Area

Model Number	Surface Area in Sq.ft.		Model Number	Surface Area in Sq.ft.		Model Number	Surface Area in Sq.ft.		Model Number	Surface Area in Sq.ft.	
	3/8" O.D Tubing	5/8 O.D Tubing		3/8" O.D Tubing	5/8 O.D Tubing		3/8" O.D Tubing	5/8 O.D Tubing		3/8" O.D Tubing	5/8 O.D Tubing
CS-2436	153.2	82.5	CS-3248	334.6	185.9	CS-4048	540.4	301.1	CS-4848	793.2	442.4
CS-2448	204.2	110.0	CS-3260	418.2	232.3	CS-4060	675.4	376.3	CS-4860	991.6	553.0
CS-2460	255.3	137.4	CS-3272	501.9	278.8	CS-4072	810.5	451.6	CS-4872	1189.9	663.7
CS-2472	306.3	164.9	CS-3284	585.5	325.3	CS-4084	945.6	526.9	CS-4884	1388.2	774.3
CS-2484	357.4	192.4	CS-3296	669.1	371.8	CS-4096	1080.7	602.1	CS-4896	1586.5	884.9
CS-2496	408.4	219.9	CS-32108	752.8	418.2	CS-40108	1215.8	677.4	CS-48108	1784.8	995.5
CS-24108	459.5	247.4	CS-32120	836.4	464.7	CS-40120	1350.9	752.7	CS-48120	1983.1	1106.1
CS-24120	510.5	274.9	CS-32132	920.1	511.2	CS-40132	1486.0	827.9	CS-48132	2181.4	1216.7
CS-2848	251.3	138.8	CS-3648	432.0	240.9	CS-4448	661.3	361.3			
CS-2860	314.2	173.4	CS-3660	540.0	301.1	CS-4460	826.6	451.6			
CS-2872	377.0	208.1	CS-3672	647.9	361.3	CS-4472	991.9	541.9			
CS-2884	439.8	242.8	CS-3684	755.9	421.5	CS-4484	1157.3	632.2			
CS-2896	502.7	277.5	CS-3696	863.9	481.7	CS-4496	1322.6	722.6			
CS-28108	565.5	312.2	CS-36108	971.9	541.9	CS-44108	1487.9	812.9			
CS-28120	628.3	346.9	CS-36120	1079.9	602.1	CS-44120	1653.2	903.2			
CS-28132	691.1	381.6	CS-36132	1187.9	662.4	CS-44132	1818.5	993.5			

note: AIHTI reserves the right to make reasonable design changes without notice.

CS-2400 Series *dimensions*

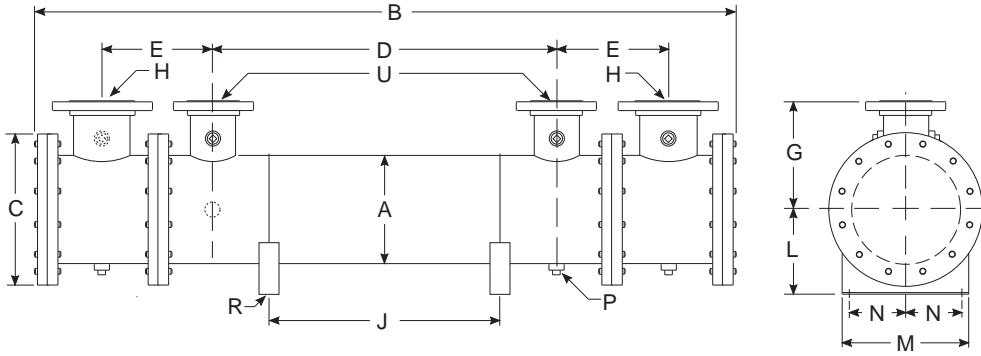

Model	B	E	H
CS-2436	68.00	14.44	8.00" ANSI Flange 150# RF
CS-2448	80.00		
CS-2460	92.00		
CS-2472	104.00		
CS-2484	116.00		
CS-2496	128.00		
CS-24108	140.00		
CS-24120	152.00		

Single Pass (SP)

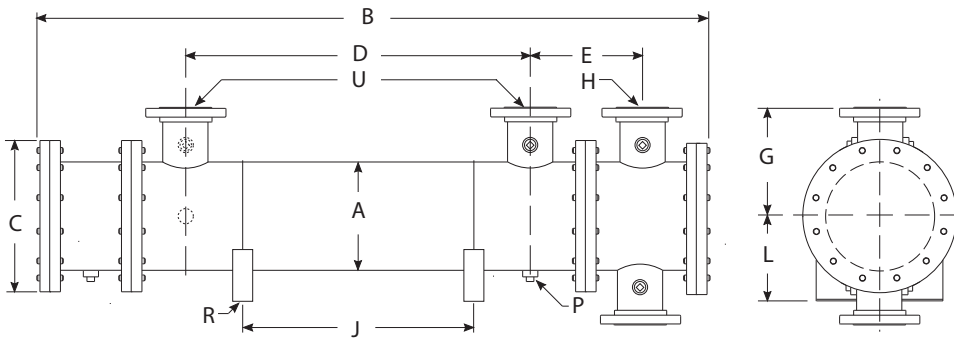

Model	B	E	H
CS-2436	63.00	14.44	6.00" ANSI Flange 150# RF
CS-2448	75.00		
CS-2460	87.00		
CS-2472	99.00		
CS-2484	111.00		
CS-2496	123.00		
CS-24108	135.00		
CS-24120	147.00		

Two Pass (TP)

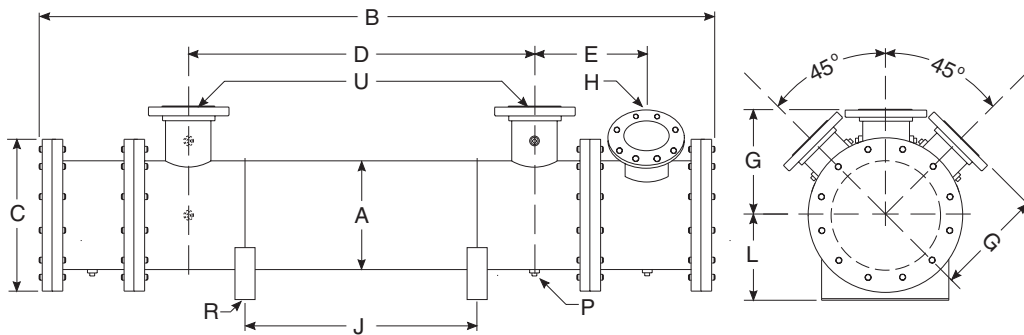

Model	B	E	H
CS-2436	63.00	14.44	4.00" ANSI Flange 150# RF
CS-2448	75.00		
CS-2460	87.00		
CS-2472	99.00		
CS-2484	111.00		
CS-2496	123.00		
CS-24108	135.00		
CS-24120	147.00		

Four Pass (FP)

COMMON DIMENSIONS & WEIGHTS

Model	A	C	D	G	J adjustable	L	M	N	P NPT	R	U	Weight	Model
CS-2436	12.75	16.25	24.00	11.38	12.00	12.00	14.75	5.00	(10) .50	.75"Ø x 1.00" Thru Slot	6.00" ANSI Flange 150# RF	1040	CS-2436
CS-2448			36.00		24.00							1130	CS-2448
CS-2460			48.00		36.00							1221	CS-2460
CS-2472			60.00		48.00							1312	CS-2472
CS-2484			72.00		60.00							1402	CS-2484
CS-2496			84.00		72.00							1493	CS-2496
CS-24108			96.00		84.00							1584	CS-24108
CS-24120			108.00		96.00							1675	CS-24120

note: AIHTI reserves the right to make reasonable design changes without notice.

Copyright © 2019 - 2020 American Industrial Heat Transfer, Inc. 355 American Industrial Drive LaCrosse, VA 23950 tel: 434-757-1800 fax: 434-757-1810 email: sales@aihti.com

CS-2800 Series *dimensions*

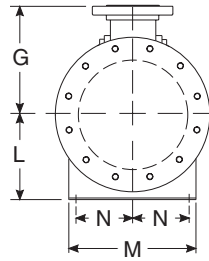
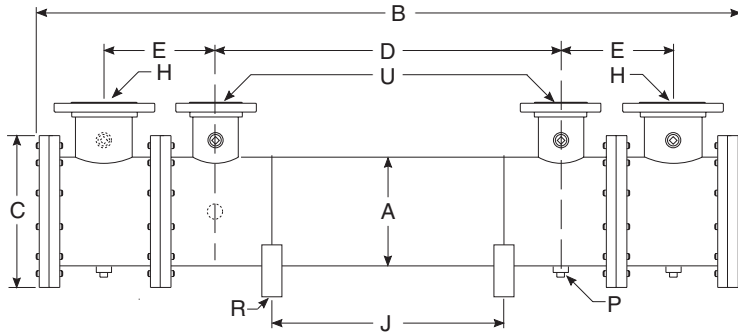

Model	B	E	H
CS-2836	68.00	15.44	8.00" ANSI Flange 150# RF
CS-2848	80.00		
CS-2860	92.00		
CS-2872	104.00		
CS-2884	116.00		
CS-2896	128.00		
CS-28108	140.00		
CS-28120	152.00		
CS-28132	164.00		

Single Pass (SP)

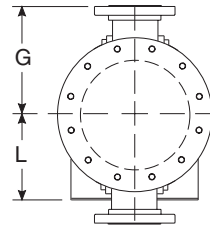
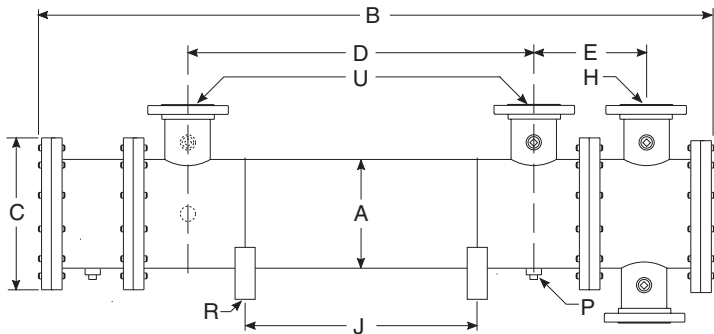

Model	B	E	H
CS-2836	64.00	15.44	6.00" ANSI Flange 150# RF
CS-2848	76.00		
CS-2860	88.00		
CS-2872	100.00		
CS-2884	112.00		
CS-2896	124.00		
CS-28108	136.00		
CS-28120	148.00		
CS-28132	160.00		

Two Pass (TP)

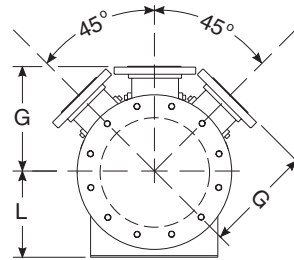
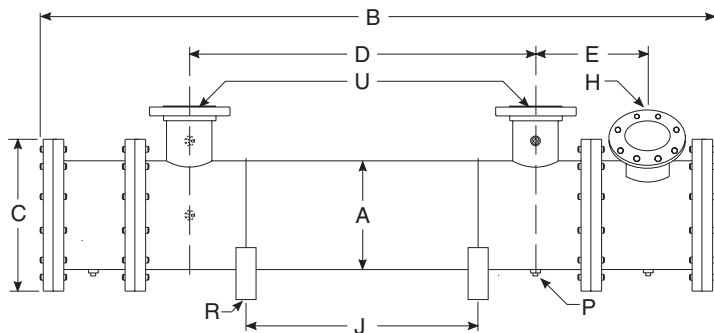

Model	B	E	H
CS-2836	64.00	15.44	4.00" ANSI Flange 150# RF
CS-2848	76.00		
CS-2860	88.00		
CS-2872	100.00		
CS-2884	112.00		
CS-2896	124.00		
CS-28108	136.00		
CS-28120	148.00		
CS-28132	160.00		

Four Pass (FP)

COMMON DIMENSIONS & WEIGHTS

Model	A	C	D	G	J adjustable	L	M	N	P NPT	R	U	Weight	Model
CS-2836	14.00	18.00	22.00	13.00	6.00	13.00	16.00	5.00	(10) .50	.75"Ø x 1.00" Thru Slot	8.00" ANSI Flange 150# RF	1288	CS-2836
CS-2848			34.00		18.00							1400	CS-2848
CS-2860			46.00		30.00							1512	CS-2860
CS-2872			58.00		42.00							1624	CS-2872
CS-2884			70.00		54.00							1736	CS-2884
CS-2896			82.00		66.00							1848	CS-2896
CS-28108			94.00		78.00							1960	CS-28108
CS-28120			106.00		90.00							2072	CS-28120
CS-28132	118.00	102.00	2184	CS-28132									

CS-3200 Series *dimensions*

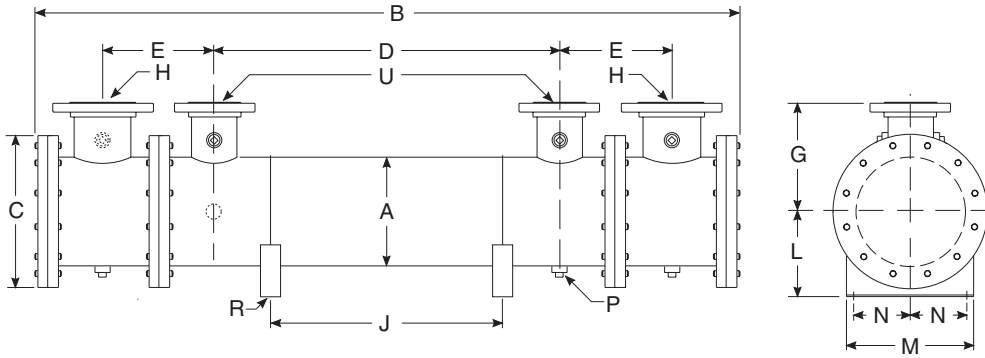

Model	B	E	H
CS-3248	85.00	17.00	10.00" ANSI Flange 150# RF
CS-3260	97.00		
CS-3272	109.00		
CS-3284	121.00		
CS-3296	133.00		
CS-32108	145.00		
CS-32120	157.00		
CS-32132	169.00		

Single Pass (SP)

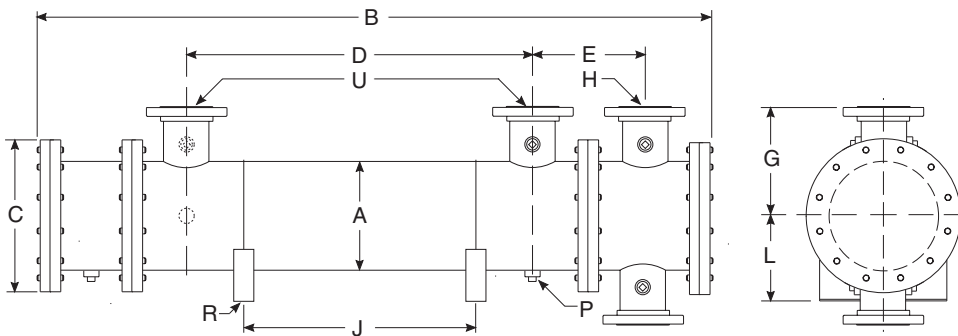

Model	B	E	H
CS-3248	80.00	17.00	6.00" ANSI Flange 150# RF
CS-3260	92.00		
CS-3272	104.00		
CS-3284	116.00		
CS-3296	128.00		
CS-32108	140.00		
CS-32120	152.00		
CS-32132	164.00		

Two Pass (TP)

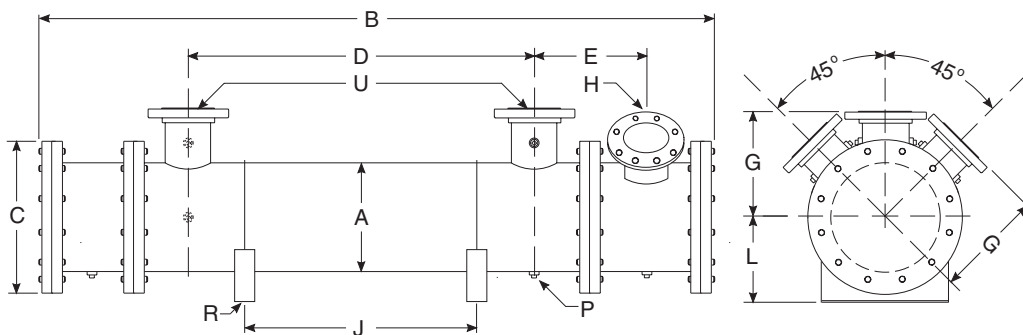

Model	B	E	H
CS-3248	80.00	17.00	5.00" ANSI Flange 150# RF
CS-3260	92.00		
CS-3272	104.00		
CS-3284	116.00		
CS-3296	128.00		
CS-32108	140.00		
CS-32120	152.00		
CS-32132	164.00		

Four Pass (FP)

COMMON DIMENSIONS & WEIGHTS

Model	A	C	D	G	J adjustable	L	M	N	P NPT	R	U	Weight	Model
CS-3248	16.00	20.00	34.00	13.00	18.00	14.00	18.00	6.00	(10) .50	.781"Ø x 1.50" Thru Slot	8.00" ANSI Flange 150# RF	2377	CS-3248
CS-3260			46.00		30.00							1975	CS-3260
CS-3272			58.00		42.00							2121	CS-3272
CS-3284			70.00		54.00							2266	CS-3284
CS-3296			82.00		66.00							2412	CS-3296
CS-32108			94.00		78.00							2558	CS-32108
CS-32120			106.00		90.00							2705	CS-32120
CS-32132			118.00		102.00							2852	CS-32132

note: AIHTI reserves the right to make reasonable design changes without notice.

Copyright © 2019 - 2020 American Industrial Heat Transfer, Inc. 355 American Industrial Drive LaCrosse, VA 23950 tel: 434-757-1800 fax: 434-757-1810 email: sales@aihti.com

CS-3600 Series *dimensions*

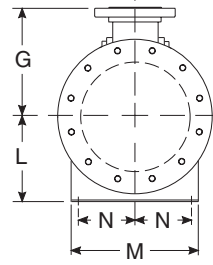
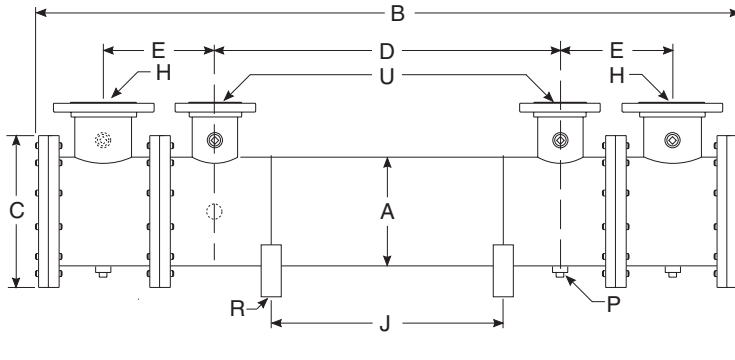

Model	B	E	H
CS-3648	85.00	18.00	10.00" ANSI Flange 150# RF
CS-3660	97.00		
CS-3672	109.00		
CS-3684	121.00		
CS-3696	133.00		
CS-36108	145.00		
CS-36120	157.00		
CS-36132	169.00		

Single Pass (SP)

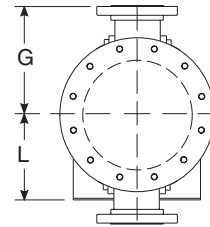
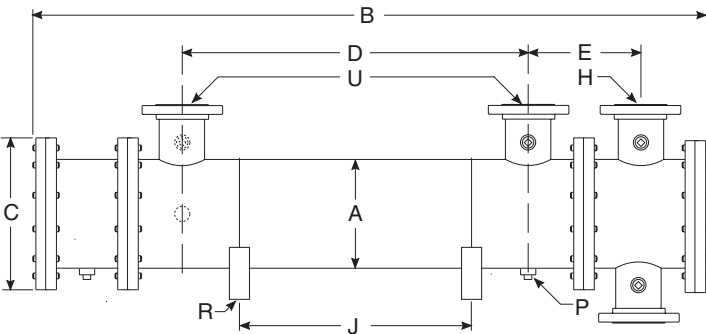

Model	B	E	H
CS-3648	81.50	18.00	8.00" ANSI Flange 150# RF
CS-3660	93.50		
CS-3672	105.50		
CS-3684	117.50		
CS-3696	129.50		
CS-36108	141.50		
CS-36120	153.50		
CS-36132	165.50		

Two Pass (TP)

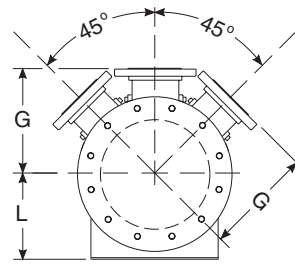
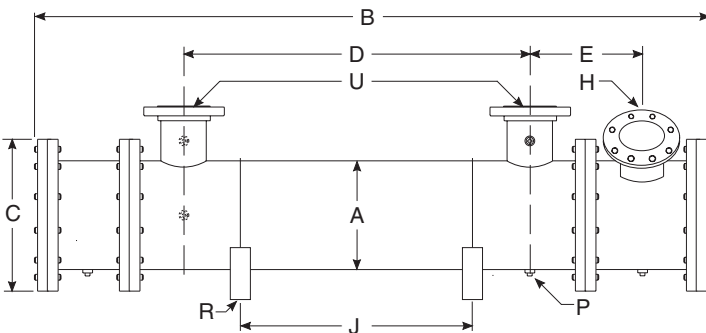

Model	B	E	H
CS-3648	81.50	18.00	5.00" ANSI Flange 150# RF
CS-3660	93.50		
CS-3672	105.50		
CS-3684	117.50		
CS-3696	129.50		
CS-36108	141.50		
CS-36120	153.50		
CS-36132	165.50		

Four Pass (FP)

COMMON DIMENSIONS & WEIGHTS

Model	A	C	D	G	J adjustable	L	M	N	P NPT	R	U	Weight	Model
CS-3648	18.00	22.00	32.00	13.00	12.00	15.00	20.00	7.00	.50	.781"Ø x 1.50" Thru Slot	10.00" ANSI Flange 150# RF	2314	CS-3648
CS-3660			44.00		24.00							2498	CS-3660
CS-3672			56.00		36.00							2684	CS-3672
CS-3684			68.00		48.00							2869	CS-3684
CS-3696			80.00		60.00							3054	CS-3696
CS-36108			92.00		72.00							3239	CS-36108
CS-36120			104.00		84.00							3424	CS-36120
CS-36132			116.00		96.00							3609	CS-36132

CS-4000 Series *dimensions*

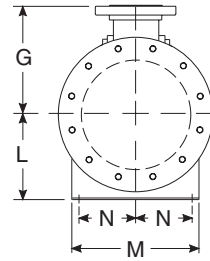
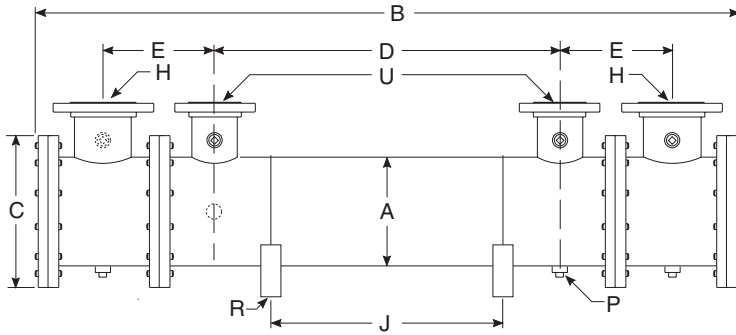

Model	B	E	H
CS-4048	91.00	19.50	12.00" ANSI Flange 150# RF
CS-4060	103.00		
CS-4072	115.00		
CS-4084	127.00		
CS-4096	139.00		
CS-40108	151.00		
CS-40120	163.00		
CS-40132	175.00		

Single Pass (SP)

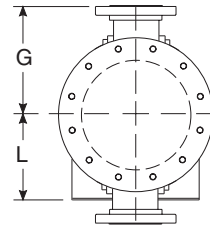
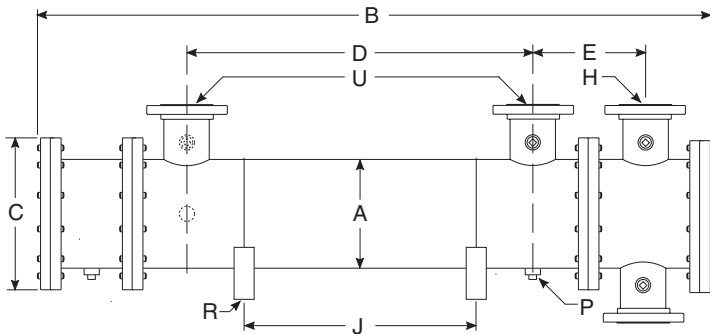

Model	B	E	H
CS-4048	86.50	19.50	8.00" ANSI Flange 150# RF
CS-4060	98.50		
CS-4072	110.50		
CS-4084	122.50		
CS-4096	134.50		
CS-40108	146.50		
CS-40120	158.50		
CS-40132	170.50		

Two Pass (TP)

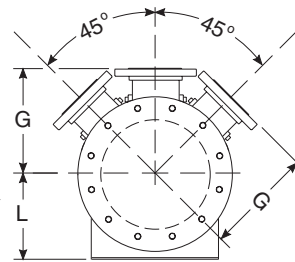
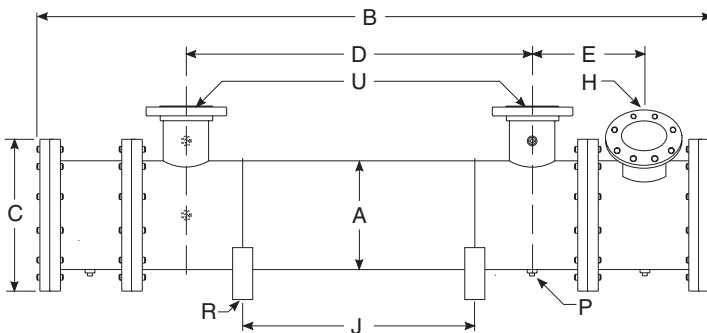

Model	B	E	H
CS-4048	86.50	19.50	6.00" ANSI Flange 150# RF
CS-4060	98.50		
CS-4072	110.50		
CS-4084	122.50		
CS-4096	134.50		
CS-40108	146.50		
CS-40120	158.50		
CS-40132	170.50		

Four Pass (FP)

COMMON DIMENSIONS & WEIGHTS

Model	A	C	D	G	J adjustable	L	M	N	P NPT	R	U	Weight	Model
CS-4048	20.00	25.00	32.00	16.00	12.00	17.00	22.00	8.00	.50	.781"Ø x 1.50" Thru Slot	10.00" ANSI Flange 150# RF	2856	CS-4048
CS-4060			44.00		24.00							3085	CS-4060
CS-4072			56.00		36.00							3313	CS-4072
CS-4084			68.00		48.00							3542	CS-4084
CS-4096			80.00		60.00							3770	CS-4096
CS-40108			92.00		72.00							3999	CS-40108
CS-40120			104.00		84.00							4227	CS-40120
CS-40132			116.00		96.00							4456	CS-40132

note: AIHTI reserves the right to make reasonable design changes without notice.

CS-4400 Series *dimensions*

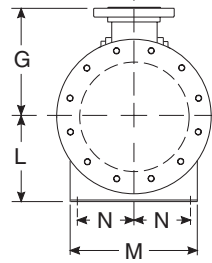
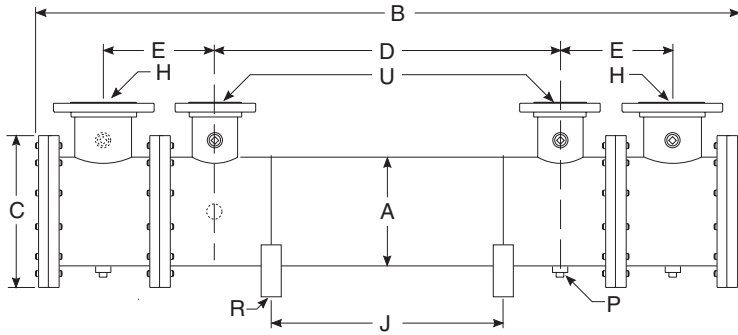

Model	B	E	H
CS-4448	95.00	21.63	14.00" ANSI Flange 150# RF
CS-4460	107.00		
CS-4472	119.00		
CS-4484	131.00		
CS-4496	143.00		
CS-44108	155.00		
CS-44120	167.00		
CS-44132	179.00		

Single Pass (SP)

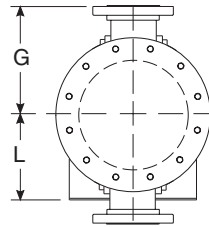
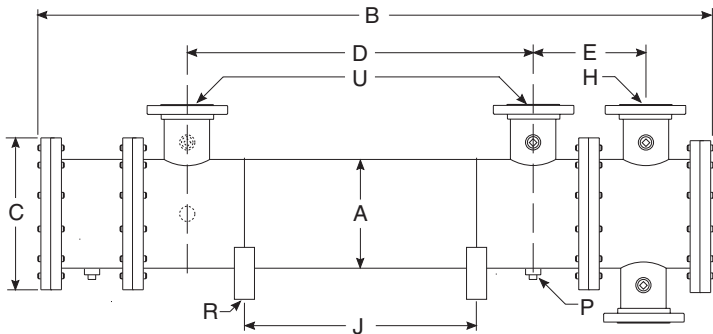

Model	B	E	H
CS-4448	90.00	21.63	10.00" ANSI Flange 150# RF
CS-4460	102.00		
CS-4472	114.00		
CS-4484	126.00		
CS-4496	138.00		
CS-44108	150.00		
CS-44120	162.00		
CS-44132	174.00		

Two Pass (TP)

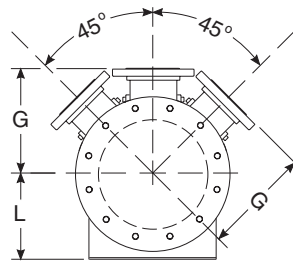
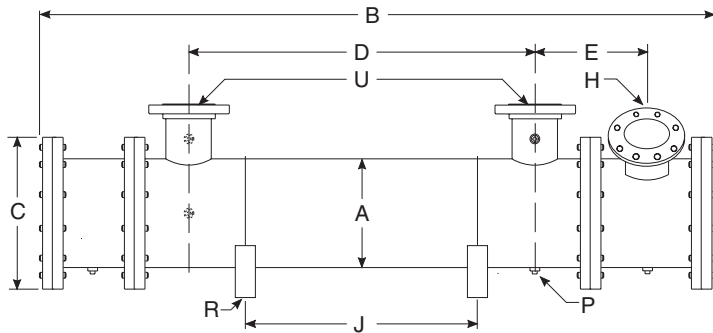

Model	B	E	H
CS-4448	90.00	21.63	6.00" ANSI Flange 150# RF
CS-4460	102.00		
CS-4472	114.00		
CS-4484	126.00		
CS-4496	138.00		
CS-44108	150.00		
CS-44120	162.00		
CS-44132	174.00		

FOUR PASS (FP)

COMMON DIMENSIONS & WEIGHTS

Model	A	C	D	G	J adjustable	L	M	N	P NPT	R	U	Weight	Model
CS-4448	22.00	28.00	29.00	17.00	5.00	18.00	24.00	8.50	.50	.781"Ø x 1.50" Thru Slot	12.00" ANSI Flange 150# RF	3456	CS-4448
CS-4460			41.00		17.00							3733	CS-4460
CS-4472			53.00		29.00							4099	CS-4472
CS-4484			65.00		41.00							4285	CS-4484
CS-4496			77.00		53.00							4562	CS-4496
CS-44108			89.00		65.00							4839	CS-44108
CS-44120			101.00		77.00							5115	CS-44120
CS-44132			113.00		89.00							5391	CS-44132

CS-4800 Series *dimensions*

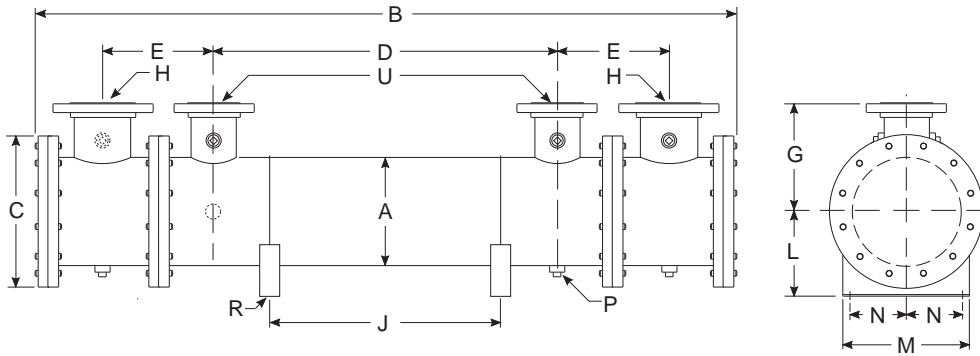

Model	B	E	H
CS-4848	95.00	21.63	14.00" ANSI Flange 150# RF
CS-4860	107.00		
CS-4872	119.00		
CS-4884	131.00		
CS-4896	143.00		
CS-48108	155.00		
CS-48120	167.00		
CS-48132	179.00		

Single Pass (SP)

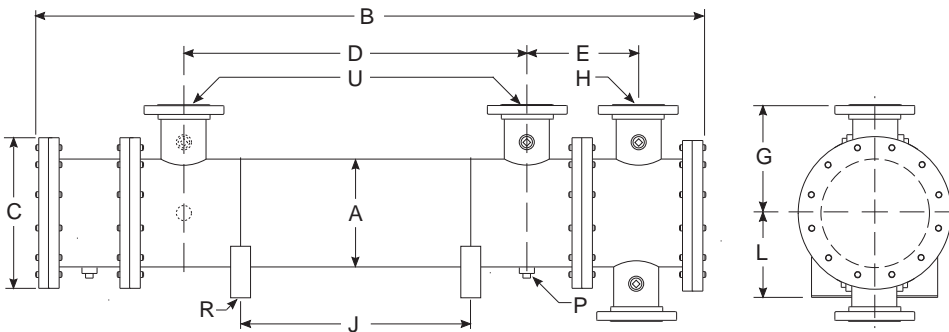

Model	B	E	H
CS-4848	91.50	21.63	10.00" ANSI Flange 150# RF
CS-4860	103.50		
CS-4872	115.50		
CS-4884	127.50		
CS-4896	139.50		
CS-48108	151.50		
CS-48120	163.50		
CS-48132	175.50		

Two Pass (TP)

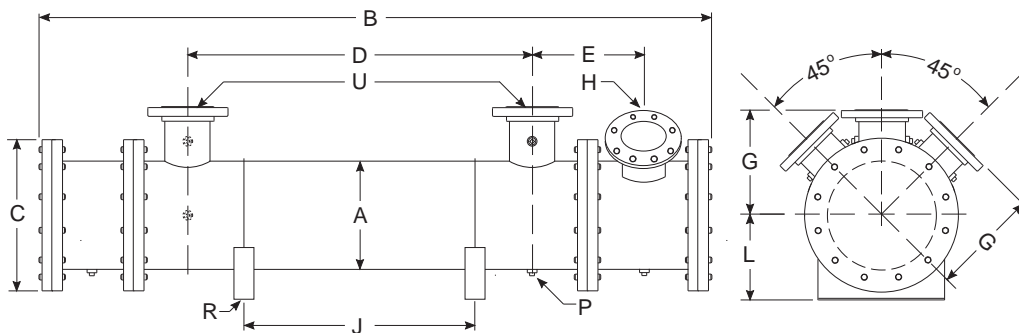

Model	B	E	H
CS-4848	91.50	21.63	8.00" ANSI Flange 150# RF
CS-4860	103.50		
CS-4872	115.50		
CS-4884	127.50		
CS-4896	139.50		
CS-48108	151.50		
CS-48120	163.50		
CS-48132	175.50		

FOUR PASS (FP)

COMMON DIMENSIONS & WEIGHTS

Model	A	C	D	G	J adjustable	L	M	N	P NPT	R	U	Weight	Model
CS-4848	24.00	30.00	29.00	18.00	5.00	19.00	26.00	10.00	.50	.781"Ø x 1.50" Thru Slot	12.00" ANSI Flange 150# RF	4113	CS-4848
CS-4860			41.00		17.00							4442	CS-4860
CS-4872			53.00		29.00							4771	CS-4872
CS-4884			65.00		41.00							5100	CS-4884
CS-4896			77.00		53.00							5429	CS-4896
CS-48108			89.00		65.00							5758	CS-48108
CS-48120			101.00		77.00							6087	CS-48120
CS-48132			113.00		89.00							6416	CS-48132

note: AIHTI reserves the right to make reasonable design changes without notice.

CS 2400 - CS 4800 Series *installation & maintenance*

PIPING HOOK-UP

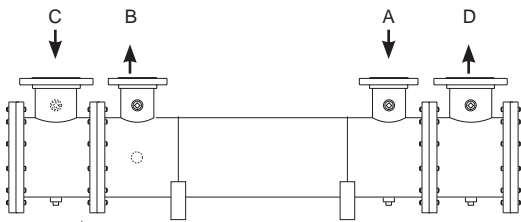

Single Pass

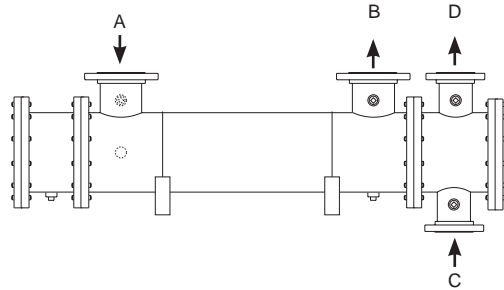

Two Pass

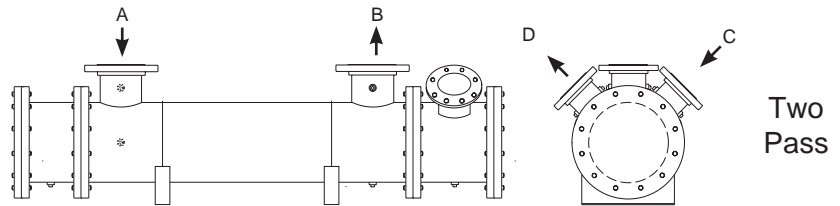

Two Pass

- A Hot fluid to be cooled
- B Cooled fluid
- C Cooling water in
- D Cooling water out

- SP Single Pass
- TP Two Pass
- FP Four Pass

Receiving / Installation

a) Inspect unit for any shipping damage before uncrating. Indicate all damages to the trucking firms' delivery person, and mark it on the receiving bill before accepting the freight. Make sure that there is no visible damage to the outside surface of the heat exchanger. The published weight information located in this brochure is approximate. True shipment weights are determined at the time of shipping and may vary. Approximate weight information published herein is for engineering approximation purposes and should not be used for exact shipping weight. Since the warranty is based upon the unit date code located on the model identification tags, removal or manipulation of the identification tags will void the manufacturer's warranty.

b) When handling the shell & tube heat exchanger, special care should be taken to avoid dropping the unit since mishandling could cause the heat exchanger to crack and leak externally. Mishandling of the unit is not covered under the manufacturer's warranty. All units are shipped with partial wood/corrugated cardboard containers for safe handling.

c) Storage: American Industrial heat exchangers are protected against the elements during shipment. If the heat exchanger cannot be installed and put into operation immediately upon receipt, certain precautions are required to prevent deterioration during storage. The responsibility for integrity of the heat exchanger(s) is assumed by the user. American Industrial will not be responsible for damage, corrosion, or other deterioration of the heat exchanger during transit or storage.

Proper storage practices are important when considering the high costs of repair or replacement, and the possible delays for items which require long lead times for manufacture. The following listed practices are provided solely as a convenience to the user, who shall make their own decision on whether to use all or any of them.

- 1) Heat exchangers not to be placed in immediate service, require precautionary measures to prevent corrosion or contamination.
- 2) Heat exchangers made of ferrous materials, may be pressure-tested using compressed air at the factory. Residual oil coating on the inside surfaces of the heat exchanger(s) as a result of flushing does not discount the possibility of internal corrosion. Upon receipt, fill the heat exchanger(s) with the appropriate grade of oil or apply a corrosion preventing inhibitor for storage.
- 3) Corrosion protection compounds for interior surfaces for long term storage or other applications are applied solely at the request of customers. Upon request, American Industrial can provide a customer approved corrosion preventative if available when included in the original purchase order specifications.

- 4) Remove all dirt, water, ice, or snow and wipe dry before moving heat exchanger(s) into storage. Heat exchangers are generally shipped empty, open drain plugs to remove any accumulated condensation moisture, then reseal. Accumulation of moisture usually indicates corrosion has already started and remedial action should be taken.
- 5) Store in a covered, environmentally stable area. The ideal storage environment for heat exchangers is in a dry, low-humidity atmosphere which is sealed to prevent the entry of blowing dust, rain, or snow. Maintain in atmospheric temperatures between 70°F and 105°F (Large temperature swings may cause condensation and moisture to form on steel components, threads, shell, etc...) Use thermometers and humidity indicators and maintain the atmosphere at 40% relative humidity, or lower.

d) Standard Enamel Coating: American Industrial provides its standard products with a normal base coat of oil base air cure enamel paint. The enamel paint is applied as a temporary protective and esthetic coating prior to shipment. While the standard enamel coating is durable, American Industrial does not warranty it as a long-term finish coating. It is strongly suggested that a more durable final coating be applied after installation or prior to long-term storage in a corrosive environment to cover any accidental scratches, enhance esthetics, and further prevent corrosion. It is the responsibility of the customer to provide regular maintenance against chips, scratches, etc... and regular touch up maintenance must be provided for long-term benefits and corrosion prevention.

e) Special Coatings: American Industrial offers as customer options, Air-Dry Epoxy, and Heresite (Air-Dry Phenolic) coatings at additional cost. American Industrial offers special coatings upon request, however American Industrial does not warranty coatings to be a permanent solution for any equipment against corrosion. It is the responsibility of the customer to provide regular maintenance against chips, scratches, etc... and regular touch up maintenance must be provided for long-term benefits and corrosion prevention.

f) American Industrial recommends that the equipment supplied should be installed by qualified personnel who have solid understanding of system design, pressure and temperature ratings, and piping assembly. Verify the service conditions of the system prior to applying any shell & tube heat exchanger. If the system pressure or temperature does not fall within the parameters on model rating tag located on the heat exchanger, contact our factory prior to installation or operation.

g) Plan the installation to meet the requirements indicated on the piping installation diagram as illustrated above. It is recommended to put the

CS 2400 - CS 4800 Series *installation & maintenance*

hot fluid to be cooled through the shell side and the cold fluid through the tube side. The indicated port assembly sequence in the diagram maximizes the performance, and minimizes the possibility of thermal shock. In instances where the fluids are required to be reversed, *hot fluid in the tubes and cold fluid in the shell* the heat exchanger will work with reduced performance. Installation may be vertical or horizontal or a combination thereof. However, the installation must allow for complete draining of the heat exchanger regardless of Single Pass, Two Pass, or four pass construction. Complete drainage is important to prevent the heat exchanger from freezing, over-heating of a fluid, or mineral deposit buildup.

For fixed bundle heat exchangers, provide sufficient clearance at one end to allow for the removal or replacement of tubes. On the opposite end, provide enough space to allow removal of the channel cover and complete channel to provide sufficient clearance to permit tube rolling and cleaning. Channel covers can be removed to aid in cleaning the tubes without disassembling channel, plumbing, or mounting hardware. Allow accessible room for scheduled cleaning as needed. Include thermometer wells and pressure gauge pipe ports in piping to and from the heat exchanger located as close to the heat exchanger as possible. For more information please contact American Industrial.

h) It is recommended to use flexible hose wherever possible to reduce vibration and allow slight movement. However, hoses are not required. Hydraulic carrying lines should be sized to handle the appropriate flow and to meet system pressure drop requirements based upon the systems parameters, and not based upon the units supply and return connection size. We recommend that a low cracking pressure direct acting relief valve be installed at the heat exchanger inlet to protect it from pressure spikes by bypassing oil in the event the system experiences a high flow surge. If preventative filtration is used it should be located ahead of the cooler on both shell and tube side to catch any scale or sludge from the system before it enters the cooler. Failure to install filters ahead of the heat exchanger could lead to possible heat exchanger failure due to high pressure if the system filters plug.

i) Standard shell & tube coolers are built with a rolled tube-sheet construction. However, the differential operating temperature between the entering shell side fluid and the entering tube side fluid should not exceed 150°F. If this condition exists, a severe thermal shock could occur leading to product failure and mixing of the fluids. For applications with a differential temperatures of 150°F or more, we recommend using a series with a floating tube-sheet, u-tube, or expansion joint to reduce the potential for the effects of thermal shock.

j) Water requirements vary from location to location. If the source of cooling water is from other than a municipal water supply, it is recommended that a water strainer be installed ahead of the heat exchanger to prevent dirt and debris from entering and clogging the flow passages. If a water modulating valve is used it is recommended to be installed at the inlet to the cooler to regulate the water flow.

k) For steam service, or other related applications, please consult our engineering department for additional information.

Maintenance

a) Inspect the heat exchanger for loosened bolts, connections, rust spots, corrosion, and for internal or external fluid leakage. Any corroded surfaces should be cleaned and recoated with paint.

b) **Shell side:** In many cases with clean hydraulic system oils it will not be necessary to flush the interior of the shell side of the cooler. In circumstances where the quality of hydraulic fluid is in question, the shell side should be disconnected and flushed on a yearly basis with a clean flushing oil/solvent to remove any sludge that has been deposited. For severe cases where the unit is plugged and cannot be flushed clean with solvent, the heat exchanger should be replaced to maintain the proper cooling performance.

c) **Tube side:** In many cases it will be necessary to clean the tube side of the heat exchanger due to poor fluid quality, debris, calcium deposits, corrosion, mud, sludge, seaweed, etc.... To clean the tube side, flush with clean water or any good quality commercial cleaner that does not attack the particular material of construction. With straight tube heat exchangers you can use a rod to carefully push any debris out of the tubes.

d) **Zinc anodes** are normally used to reduce the risk of failure due to electrolysis. Zinc anodes are a sacrificial component designed to wear and dissolve through normal use. Normally, zinc anodes are applied to the water supply side of the heat exchanger. Depending upon the amount of corrosive action, one, two, three, or more anodes can be applied to help further reduce the risk of failure. American Industrial Heat Transfer, Inc. offers zinc anodes as an option, to be specified and installed at the request of our customers. It is the responsibility of the customer to periodically check and verify the condition of the zinc anode and replace it as needed.

Applications vary due to water chemical makeup and quality, material differences, temperature, flow rate, piping arrangements, and machine grounding. For those reasons, zinc anodes do not follow any scheduled factory predetermined maintenance plan moreover they must be checked routinely by the customer, and a maintenance plan developed based upon the actual wear rate.

If substantial wear occurs or zinc dissolves without replacement, premature failure or permanent damage may occur to the heat exchanger. American Industrial does not warranty customer applications. It is the responsibility of the customer to verify and apply the proper system materials of construction and overall system requirements. Failures resulting from properly applied or misapplied use of zinc anode(s) into non-specified or specified applications will be the sole responsibility of the customer.

e) A routine maintenance schedule should be developed and adjusted to meet your systems requirements based upon water quality, etc.... Failure to regularly maintain and clean your heat exchanger can result in a reduction in operational performance and life expectancy.

Note: *Since applications can vary substantially, the installation and maintenance information contained in this catalog should be used as a basic guideline. The safe installation, maintenance, and use of any American Industrial Heat Transfer, Inc. heat exchanger are solely the responsibility of the user.*

Thermostatic Modulating Water Valve With Bulb Well Assembly (for Shell & Tube Heat Exchangers And Air/Oil Coolers)

